

# HMS Bounty “492” \* \*



## BUILDING INSTRUCTION

This model is Copyright protected.  
All Copyrights to the designs of this  
version of the HMS Bounty belongs to  
Billing Boats Denmark Aps





## H.M.S. BOUNTY (1787)

Blandt alle de mytterier, der berettes om i søfartens historie, er mytteriet på 'Bounty' det mest bemærkelsesværdige eksempel på et oprør, som omfattede hele besætningen på et krigsskib i rum sø.

'Bounty' satte sejl i Spithead i England med Tahiti som mål. Her skulle skibet laste prøver af brødfrugt-træet, som de engelske myndigheder nærrede store forventninger til. Man havde til hensigt at omplante det til de vestindiske øer for - til en lav pris - at skaffe føde til arbejderne i disse kolonier. Skibets og ekspeditionens kommandant var William Bligh. Ombord var - udover de 46 besætningsmedlemmer - også en botaniker.

I april 1789 havde skibet allerede fuldført den første del af sin mission, og med sin kostbare last sejlede det med vinden agten for tværs, da mandskabet pludselig ud for Venskabsøerne gjorde oprør. Anstifteren og lederen var Fletcher Christian, en officer, som var uenig med kaptajnen. Bligh blev sat ud i en åben båd 30 mil fra Tofua sammen med 17 loyale besætningsmedlemmer.

Oprørerne vendte tilbage til Tahiti, hvor de lastede forsyninger og kvæg, hvorefter de forlod øen. Men de vendte snart tilbage, og 14 af dem gik i land og blev på øen for at skabe en ny tilværelse. De øvrige satte igen sejl, for sammen med nogle indfødte og 12 kvinder at finde et sikrere sted at slå sig ned. De fandt det virkelig og bosatte sig på øen Pitcairn efter at have plyndret 'Bounty' for alt brugbar materiale. Idag lever Fletcher Christian og hans ledsageres lyshårede efterkommere stadig på denne ø. Bligh og hans 17 besætningsmedlemmer tilbragte 40 rædselsfulde døgn i båden, og udmarvede af sult, tørst og afsavn nåede de endelig Timor og vendte derefter hjem.

Længde	54,80m
Bredde	13,50m
Dybgang	6,40m



## H.M.S. BOUNTY (1787)

Among all those recorded through naval history, that of the Bounty is certainly the most notable example of rebellion which involved the entire crew of a warship on the high seas. The Bounty set sail at Spithead, England and was bound for Tahiti in the South Sea Islands to load samples of the bread fruit tree, on which the English authorities placed high hopes.

They in fact intended to transplant it to the West Indies to feed the workers of those colonies, mostly Negro slaves, at a cheap price. The commander of the ship and of the expedition was William Bligh. Aboard besides the 46 men of crew, was also a botanist.

In April 1789 the ship had already completed the first part of her mission and with her precious cargo she was sailing before the wind when suddenly, off the Friendly Islands, the crew mutinied. They were instigated and led by Fletcher Christian, the executive officer, who dissented from the captain.

Bligh was set adrift in an open boat 30 miles from Tofua with 17 loyal members of the crew. The mutineers returned to Tahiti where they embarked supplies and cattle and then left the Islands. However, they soon returned and 14 of them landed to remain on the Island and find a new way of life. The remainder set sail again with some natives and 12 women in search of a safer place to live. They indeed found it and settled a Pitcairn Islands after stripping the Bounty of all useful material. Today the fairhaired descendants of the colony founded by Fletcher Christian and his companions still live on that island. Bligh and the others spent 40 horrible days in the boat and exhausted by hunger, thirst and privations: they eventually reached Timor and subsequently returned home.

Lenght	54,80m
Width	13,50m
Draught	6,40m



### H.M.S. BOUNTY (1787)

Unter allen in der Seefahrt bekannt gewordenen Schiffen erweckte die Bounty durch die Meuterei Ihrer gesamten Mannschaft auf hoher See besonderes Interesse. Die Bounty lief in Spithead aus und sollte in Tahiti auf den Südseeinseln Brotbäume laden, von denen sich die englische Regierung sehr viel versprach. Man hatte vor, diese Bäume auf den Westindischen Inseln anzupflanzen und hoffte, mit der Brotfrucht ein besonders billiges Nahrungsmittel für die Arbeiter dieser Kolonien, die sich überwiegend aus Negersklaven rekrutierten, zu erhalten. Der Kapitän des Schiffes zu dessen 46 köpfiger Besatzung auch ein Botaniker gehörte, war Bligh. Im April 1789 - das Schiff hatte den ersten Teil seiner unvermittelt, als sie an den Freundschaftsinseln vorbeisegelte, unter der Mannschaft eine Meuterei aus. Der Aufruhr wurde geschürt und geleitet von Christian Fletcher, dem 1. Offizier, der sich vom Kapitän lossagte. Bligh, der Kapitän, und 17 ihm die Treue haltende Mitglieder der Mannschaft wurden in einem offenen Boot auf hoher See etwa 30 Meilen vor Tofua ausgesetzt. Die Meuterer segelten nach Tahiti zurück, wo sie Verpflegung und Vieh an Bord nahmen und gingen wieder in See. Man besann sich jedoch, kehrte noch einmal um und 14 Mann der Besatzung blieben auf der Hauptinsel zurück, um ein neues Leben anzufangen. Der Rest der Mannschaft, zusammen mit einigen Eingeborenen und 12 Frauen machten sich auf die Suche nach einer sicheren Zuflucht, die sie schliesslich auf Pitcairn fanden. Sie bauten von der Bounty alles ab, was sich nur irgendwie verwenden liess. Heute noch kann man an den blondhaarigen Nachkommen dieser Insel sehen, dass Christian Fletcher mit seinen Leuten auf dieser Insel lebte. Bligh und seine Leute brachten 40 fürchterliche Tage in Ihrem Boot auf hoher See zu, geplagt von Hunger, Durst und Witterung, bis sie endlich Timor erreichten und von dort heimkehren konnten.

Länge	54,80m
Breite	13,50m
Teifgang	6,40m



### H.M.S. BOUNTY (1787)

Dans l'histoire navale, parmi tous ceux relatés, celui du Bounty est certainement l'exemple le plus notable d'une rébellion qui souleva l'équipage entier d'un bateau de guerre en haute mer.

Le Bounty appareilla à Spithead, en Angleterre, à destination de Tahiti dans les îles des Mers du Sud pour charger des échantillons d'arbres à pain sur lesquels les autorités anglaises fondaient de grands espoirs. Elles avaient en fait l'intention de les transplanter aux Antilles pour nourrir à bas prix les ouvriers de ces colonies, pour la plupart des esclaves noirs. Le commandant du navire et de l'expédition était William Bligh. A bord, parmi les 46 membres de l'équipage, il y avait également un botaniste. En Avril 1789, le navire avait presque totalement rempli sa cargaison, avec son précieux chargement, il naviguait toutes voiles dehors quand soudain, après les îles Friendly, l'équipage se mutina. Ils étaient incités et dirigés par Fletcher Christian, l'officier en second, qui était en désaccord avec le capitaine. Bligh fut abandonné dans une chaloupe, à 30 miles de Tofua, avec 17 membres loyaux de l'équipage. Les mutins retournèrent à Tahiti où ils embarquèrent des fournitures et du bétail, puis ils quittèrent l'île. Cependant, ils y revinrent bientôt, et 14 d'entre eux débarquèrent pour rester sur l'île et y trouver une nouvelle vie. Le reste des hommes reprit la mer avec quelques indigènes et 12 femmes, à la recherche d'un endroit libre pour vivre. Ils le trouvèrent et s'installèrent sur l'île de Pitcairn après avoir délesté le Bounty de tous les matériaux utilisables. Aujourd'hui, les descendants aux cheveux clairs de la colonie fondée par Fletcher Christian et ses compagnons vivent toujours sur cette île. Bligh et les autres passèrent 40 jours horribles dans la chaloupe, épuisés par la faim, la soif et les privations, ils atteignirent finalement Timor et par la suite, ils rentrèrent chez eux.

Longueur	54,80m
Largeur	13,50m
Tirant d'eau	6,40m



## H.M.S. BOUNTY (1787)

De mouterij op de Bounty is wel het meest bekende geval van mouterij waarbij de gehele bemanning van een oorlogschip op volle zee betrokken was. De Bounty vertrok vanuit Spithead, Engeland, met als bestemming Tahiti om stekken van de broodboom te halen. De Engelse regering had het plan om deze boom in de West Indische kolonien te planten om zodoende de slaven daar, meestal negers, goedkoop te kunnen voeden. De commandant van het schip voor deze expeditie was William Bligh. Ook aan boord, naast de 46 bemanningsleden, was een botanist. In April 1789, met het eerste gedeelte van haar missie voltooid, brak er mouterij uit toen het schip ter hoogte van de Friendly Islands voer. De muiters werden aangevoerd door Fletcher Christian, de eerste officier, die het niet eens was met de behandeling van de bemanning door de kapitein. Op 30 mijl van Tofua Island werden Bligh en 17 loyale bemanningsleden in een open boot over boord gezet. Na 40 verschrikkelijke dagen in deze open boot en uitgeput door honger, dorst en de hitte, bereikten ze Timor, vandaar waar ze naar huis terugkeerden. De muiters voeren terug naar Tahiti, waar ze voorraden innamen, en verlieten het eiland weer. Ze kwamen echter spoeding weer terug en 14 van hen bleven op het eiland om te proberen een nieuw bestaan op te bouwen. De rest voer weer uit, samen met een paar Tahitianen en 12 vrouwen om een veiliger woonplaats te zoeken. Ze vonden deze inderdaad en wel op Pitcarin Island. Hier vestigden zij zich na de Bounty ontdaan te hebben van alle bruikbare materialen. Vandaag de dag leven de blonde nakomelingen van Fletcher Christian en zijn medemuiters nog steeds op dit eiland.

Lengte	54,80m
Breedte	13,50m
Diepgang	6,40m



## H.M.S. BOUNTY (1787)

Entre todos los motines que se cuentan en la historia naval lo de Bounty representa un ejemplo muy digno de atención de un motín, que comprendió toda la tripulación de un buque de guerra en alta mar.

“Bounty” salió de Spitehead en Inglaterra con destino a Tahiti.

Allí el barco debía tomar cargamento de muestras del árbol del pan, del cual las autoridades inglesas se esperaban mucho. Tenían la intención de lo importar en las Antillas para procurarse- por un precio bajo- alimentación para los trabajadores de aquellas colonias. El comandante del barco y de la expedición era William Bligh. Al bordo había, además de la tripulación de 46 personas también un botánico. En abril de 1789 el barco ya había cumplido el primer parte de su misión y navegaba con su cargaison precioso con el viento de popa cuando la tripulación de golpe se motinó a lo largo de las Islas de la Amistad. El autor y el jefe fue Fletcher Christian, un oficial que no estaba de acuerdo con el capitán. Metieron Bligh en un barco abierto a una distancia de 30 millas de Tofua con 17 miembros leales de la tripulación.

Los rebeldes volvieron a Tahiti, donde cargaron provisión y ganado, y después salieron de la isla. Pero volvieron pronto, y 14 entre ellos bajaron a tierra y se quedaron en la isla para crear una nueva existencia. Los demás se fueron de nuevo con unos nativos y 12 mujeres para buscar a un lugar más seguro. Lo encontraron en realidad y se establecieron en la isla, Pitcairn, después de un pillaje total de Bounty. Hoy viven todavía en esa isla los descendientes de Fletcher Christian y de sus compañeras. Tienen los cabellos muy rubios. Bligh y los 17 miembros de la tripulación pasaron 40 días horribles en el barco y llegaron al fin a Timor. Están muriendo de hambre. Luego regresaron en Inglaterra.

Eslora	54,80m
Manga	13,50m
Calado	6,40m



## H.M.S. BOUNTY (1787)

Tra tutte le imbarcazioni famose della storia della navigazione marittima il Bounty desta oggi un particolare interesse in seguito al memorabile ammutinamento di quasi tutto l'equipaggio in alto mare.

Il Bounty salpò da Spithead con la missione di caricare a Tahiti nei mari del sud degli alberi del pane che tanto promettenti parevano al governo britannico.

I governanti pensavano infatti di piantarli sulle isole delle Indie Occidentali nella speranza di ricavare dai loro frutti un alimento particolarmente conveniente per i lavoratori delle colonie che in grandissima parte erano schiavi.

Il capitano della nave, che annoverava tra i 46 membri dell'equipaggio anche un esperto botanico, era William Bligh. La nave aveva già percorso la prima parte del viaggio e stava passando le Isole delle Amicizie, quando nell'aprile del 1789 scoppiò improvvisamente un ammutinamento tra l'equipaggio:

l'insurrezione venne fomentata e capeggiata da Christian Fletcher, primo ufficiale del Bounty oppostosi al capitano Bligh. Bligh e 17 marinai che gli erano rimasti fedeli vennero abbandonati su una scialuppa in alto mare, a una trentina di miglia davanti alle coste dell'isola di Tofua.

Gli ammutinati tornarono invece indietro a Tahiti ove caricarono cibo e bestiame, per poi salpare nuovamente. Alcuni ebbero tuttavia un ripensamento e 14 di loro decisero di rimanere sull'isola principale, intenzionati a cominciare una nuova vita. Il resto del equipaggio insieme ad alcuni indigeni e 12 donne si mise a cercare un rifugio sicuro che infine trovarono sull'isola di Pitcairn.

Dal Bounty smontarono qualunque cosa potesse esser loro utile e si stabilirono per sempre sull'isola. Il capitano Bligh ed i suoi fedeli dovettero invece trascorrere 40 giorni terribili a bordo della scialuppa, tormentati da sete, fame ed in balia delle onde ed intemperie, finché non raggiunsero l'isola di Timor.

Da lì poterono affrontare il viaggio di ritorno.

I capelli biondi di molti abitanti del posto sono ancor oggi prova tangibile, per così dire, della presenza di Christian Fletcher e dei suoi uomini su quell'isola remota.

Lunghezza: 54,80m  
Larghezza: 13,50m  
Immersione: 6,40m



## H.M.S. BOUNTY (1787)

Entre todos os motins descritos na história da navegação, o de 'Bounty' é o exemplo mais remarcável de uma revolta abrangendo toda a tripulação de um navio de guerra em alto mar. O 'Bounty' zarpou de Spithead, na Inglaterra, com destino a Tahiti. Ali, o barco carregaria mudas de fruta-pão, relativamente à qual as autoridades inglesas tinham grandes expectativas.

A intenção era plantá-la nas Índias Ocidentais, para conseguir um alimento de baixo custo para os trabalhadores dessas colônias. O comandante do barco e da expedição era William Bligh.

Além dos 46 tripulantes, havia a bordo também um botânico.

Em abril de 1789, o barco já tinha cumprido a primeira parte de sua missão e, com a sua preciosa carga, zarpou com o vento em popa, quando a tripulação de repente se amotinou na altura das Ilhas da Amizade. O instigador e líder era Fletcher Christian, um oficial que discordava do capitão.

O capitão Bligh foi colocado num barco aberto, a 30 milhas de Tofua, juntamente com 17 tripulantes leais. Os amotinados voltaram para Tahiti, onde carregaram mantimentos e gado, após o qual deixaram a ilha. Mas, logo voltaram, e 14 deles desembarcaram e ficaram na ilha para criar uma nova vida. Os demais zarparam novamente para, junto com alguns nativos e 12 mulheres, encontrarem um lugar mais seguro para ficar.

De fato acharam o lugar desejado, fixando residência na ilha Pitcairn, depois de ter saqueado todo o material útil do 'Bounty'. Hoje, os loiros descendentes de Fletcher Christian e seus comparsas ainda vivem nessa ilha.

O capitão Bligh e seus 17 tripulantes passaram 40 dias horrorosos no barco e, quase mortos de fome, sede e privações, chegaram a Timor, retornando depois para a Inglaterra

Comprimento 54,80m  
Largura 13,50m  
Calado 6,40m



Table of contents for "Bounty" Art. No. 492.

Pcs.	No.	Dimension	Material	DK	GB	D	F
1	1	4mm x-veneér	1087L	Spant	Frame	Spant	Couples
1	2	4mm x-veneér	1087L	Spant	Frame	Spant	Couples
1	3	4mm x-veneér	1088L	Spant	Frame	Spant	Couples
1	4	4mm x-veneér	1087L	Spant	Frame	Spant	Couples
1	5	4mm x-veneér	1088L	Spant	Frame	Spant	Couples
1	6	4mm x-veneér	1087L	Spant	Frame	Spant	Couples
1	7	4mm x-veneér	1087L	Spant	Frame	Spant	Couples
1	8	4mm x-veneér	1088L	Spant	Frame	Spant	Couples
1	9	4mm x-veneér	1088L	Spant	Frame	Spant	Couples
1	10	4mm x-veneér	1087L	Spant	Frame	Spant	Couples
1	11	4mm x-veneér	1087L	Stævn	Bow	Vorsteven	Etrave
1	12	4mm x-veneér	1087L	Agterstævn	Sternpost	Achtersteven	Pièce de proue
1	13	4mm x-veneér	1087L	Spant	Frame	Spant	Couples
1	14	4mm x-veneér	1087L	Spant	Frame	Spant	Couples
2	14a	4mm x-veneér	1087L	Hjælpeestykke	Auxiliary piece	Hilfstücke	Pièce annexes
2	15	4mm x-veneér	1088L	Spant	Frame	Spant	Couples
2	16	4mm x-veneér	1088L	Spant	Frame	Spant	Couples
2	17	4mm x-veneér	1088L	Spant	Frame	Spant	Couples
1	18	4mm x-veneér	1087L	Mastfod	Maststep	Mastfuss	Support de mât
1	19	4mm x-veneér	1087L	Mastfod	Maststep	Mastfuss	Support de mât
1	20	4mm x-veneér	1087L	Mastfod	Maststep	Mastfuss	Support de mât
1	21	4mm x-veneér	1087L	Ror	Rudder	Ruder	Gouvernail
1	22	4mm x-veneér	1087L	Hjælpeestykke	Auxiliary piece	Hilfstücke	Pièce annexes
2	23	2mm x-veneér	1090L-A	Dæk	Deck	Deck	Pont
2	24	2mm x-veneér	1090L-B	Hjælpeestykke	Auxiliary piece	Hilfstücke	Pièce annexes
2	25	2mm x-veneér	1090L-A	Hjælpeestykke	Auxiliary piece	Hilfstücke	Pièce annexes
2	26a	2mm x-veneér	1090L-A	Ror	Rudder	Ruder	Gouvernail
2	27	2mm x-veneér	1090L-A	Beklædning	Plankingstrip	Beplankung	Baguette de bordé
2	28a	2mm x-veneér	1090L-B	Kahyt	Cabin	Kajüte	Cabine
4	28b	2mm x-veneér	1090L-B	Kahyt	Cabin	Kajüte	Cabine
2	28c	2mm x-veneér	1090L-A	Kahyt	Cabin	Kajüte	Cabine
2	28d	2mm x-veneér	1090L-B	Kahyt	Cabin	Kajüte	Cabine
1	28e	2mm x-veneér	1090L-B	Ræling	Reling	Reling	Plat bord
2	29	2mm x-veneér	1090L-A	Kahyt	Cabin	Kajüte	Cabine

3	29	2mm x-veneér	1090L-B	Kahyt	Cabin	Kajüte	Cabine
2	30	2mm x-veneér	1090L-A	Luge	Hatch	Luke	Ecoutille
1	31	2mm x-veneér	1090L-A	Luge	Hatch	Luke	Ecoutille
6	32	2mm x-veneér	1090L-A	Spil	Winch	Winde	Treuil
4	33	2mm x-veneér	1090L-A	Luge	Hatch	Luke	Ecoutille
2	34	2mm x-veneér	1090L-B	Mærs	Top	Mars	Hune
2	35	2mm x-veneér	1090L-B	Kindbakker	Gripes	Knaggen	Jottereaux
2	36	2mm x-veneér	1090L-B	Kindbakker	Gripes	Knaggen	Jottereaux
2	37	2mm x-veneér	1090L-A	Mærs	Top	Mars	Hune
2	38	2mm x-veneér	1090L-A	Kindbakker	Gripes	Knaggen	Jottereaux
2	39	2mm x-veneér	1090L-B	Kindbakker	Gripes	Knaggen	Jottereaux
1	40	2mm x-veneér	1090L-A	Mærs	Top	Mars	Hune
1	40	2mm x-veneér	1090L-B	Mærs	Top	Mars	Hune
2	41	2mm x-veneér	1090L-B	Kindbakker	Gripes	Knaggen	Jottereaux
1	42	2mm x-veneér	1090L-A	Spant	Frame	Spant	Couples
1	43	2mm x-veneér	1090L-A	Spant	Frame	Spant	Couples
2	44	2mm x-veneér	1090L-A	Røstbræt	Chainboard	Rüstbrett	Cadénes grand mât
2	45	2mm x-veneér	1090L-B	Røstbræt	Chainboard	Rüstbrett	Cadénes grand mât
2	46	2mm x-veneér	1090L-B	Røstbræt	Chainboard	Rüstbrett	Cadénes grand mât
2	47	2mm x-veneér	1090L-B	Ræling	Reling	Reling	Plat bord
2	48	2mm x-veneér	1090L-A	Spil	Winch	Winde	Treuil
2	49	2mm x-veneér	1090L-A	Spil	Winch	Winde	Treuil
2	50	2mm x-veneér	1090L-A	Gaffel	Gaff	Gaffel	Corne
1	51	3mm x-veneér	1089L	Stævntstykker	Bowpieces	Stücke f. Vorsteven	Pièce pour etrave
1	52a	3mm x-veneér	1089L	Agterstævn	Sternpost	Achtersteven	Pièce de proue
2	52b	3mm x-veneér	1089L	Agterstævn	Sternpost	Achtersteven	Pièce de proue
2	52c	3mm x-veneér	1089L	Agterstævn	Sternpost	Achtersteven	Pièce de proue
4	53	3mm x-veneér	1089L	Spant	Frame	Spant	Couples
6	54	3mm x-veneér	1089L	Spant	Frame	Spant	Couples
12	54a	3mm x-veneér	1089L	Spant	Frame	Spant	Couples
4	55a	3mm x-veneér	1089L	Galion	Figure	Galion	Figure
2	55b	3mm x-veneér	1089L	Galion	Figure	Galion	Figure
2	56	3mm x-veneér	1089L	Galleri	Gallery	Galerie	Galerie
2	57	3mm x-veneér	1089L	Rorstand	Steering stand	Ruderstand	Capot de timonerie de gouvernail
3	58	3mm x-veneér	1089L	Bedding	Slip	Helling	Cale
4	59	3mm x-veneér	1089L	Konsol	Bracket	Halter	Console
2	60	3mm x-veneér	1089L	Mærs	Top	Mars	Hune

2	61	3mm x-veneér	1089L	Mærs	Top	Mars	Hune
2	62	3mm x-veneér	1089L	Mærs	Top	Mars	Hune
2	63	3mm x-veneér	1089L	Salling	Cross tree	Saling	Barre de hune
2	64	3mm x-veneér	1089L	Salling	Cross tree	Saling	Barre de hune
1	65	3mm x-veneér	1089L	Æselhoved	Cap	Eselshaupt	Chouquet
1	66	3mm x-veneér	1089L	Æselhoved	Cap	Eselshaupt	Chouquet
1	67	3mm x-veneér	1089L	Æselhoved	Cap	Eselshaupt	Chouquet
2	68	3mm x-veneér	1089L	Konsol	Bracket	Halter	Console
1	69	3mm x-veneér	1089L	Mastfod	Maststep	Mastfuss	Support de mât
1	70	3mm x-veneér	1089L	Mastfod	Maststep	Mastfuss	Support de mât
1	71	3mm x-veneér	1089L	Mastfod	Maststep	Mastfuss	Support de mât
1	72	3mm x-veneér	1089L	Æselhoved	Cap	Eselshaupt	Chouquet
1	73	3mm x-veneér	1089L	Æselhoved	Cap	Eselshaupt	Chouquet
1	74	3mm x-veneér	1089L	Æselhoved	Cap	Eselshaupt	Chouquet
1	75	3mm x-veneér	1089L	Spil	Winch	Winde	Treuil
1	76	3mm x-veneér	1089L	Klods	Block	Block	Poulie
2	77	3mm x-veneér	1089L	For ruller	For pulley	Für Rollen	Pour poulies
1	78	3mm x-veneér	1089L	Galge	Gallows	Galgen	Potences
1	79	3mm x-veneér	1089L	Rorstamme	Rudder stock	Ruderstamm	Arbre étambot de gouvernail
1	80	3mm x-veneér	1089L	Mellemstykke	Middelpiece	Zwischenstücke	Pièce centrales
10	81	1mm x-veneér	1091L	Galleri	Gallery	Galerie	Galerie
1	82	1mm x-veneér	1091L	Jomfru	Dead eyes	Jungfern	Cap de mouton
1	83	1mm x-veneér	1091L	Spil	Winch	Winde	Treuil
1	84	1mm x-veneér	1091L	Spil	Winch	Winde	Treuil
6	85	1mm x-veneér	1091L	Spil	Winch	Winde	Treuil
2	86	1mm x-veneér	1091L	Kofilnaglebænk	Belaying pin bench	Belegnägelbank	Ratelier d'cordage
1	87	1mm x-veneér	1091L	Kofilnaglebænk	Belaying pin bench	Belegnägelbank	Ratelier d'cordage
2	88	1mm x-veneér	1091L	Kofilnaglebænk	Belaying pin bench	Belegnägelbank	Ratelier d'cordage
3	89	1mm x-veneér	1091L	Kofilnaglebænk	Belaying pin bench	Belegnägelbank	Ratelier d'cordage
2	90	2mm x-veneér	1090L-A	Redningsbåd	Lifeboat	Rettungsboot	Canot de sauvetage
2	91	1mm x-veneér	1091L	Klyds	Hawseholes	Klüsen	Ecubiérs
17	92	1mm x-veneér	1091L	For bom	For bar	Für Baum	Pour bombe
14	93	1mm x-veneér	1091L	Lejder	Ladder	Leiter	Echelle
2	94	1mm x-veneér	1091L	Rorstand	Steering stand	Ruderstand	Capot de timonde de gouvernail
1	95	1mm x-veneér	1091L	Galleri	Gallery	Galerie	Galerie
1	96	1mm x-veneér	1091L	Galleri	Gallery	Galerie	Galerie
2	97	1mm x-veneér	1091L	Galion	Figure	Galion	Figure



2	98	1mm x-veneér	1091L	Galion	Figure	Galion	Figure
3	99	4mm x-veneér	1087L	Galionsfigur	Figurehead	Galionsfigur	Figure de proue
2	100	4mm x-veneér	1088L	Pullert	Bollard	Poller	Bitte d'armarrage
1	101	4mm x-veneér	1087L	For klokke	For bell	Für Glocke	Pour cloche
2	102	4mm x-veneér	1087L	Spil	Winch	Winde	Treuil
2	103	4mm x-veneér	1088L	Bedding	Slip	Helling	Cale
2	104	4mm x-veneér	1087L	Mellemstykke	Middle piece	Zwischenstücke	Pièce centrales
1	105	50x120mm		Acetat	Acetate	Azetat	Rhoidoid
1	106	4x14x500mm	Obechi	Liste	Strip	Leiste	Baguette
1	107	4x4x600mm	Obechi	Liste	Strip	Leiste	Baguette
3	108	3x8x550mm	Obechi	Liste	Strip	Leiste	Baguette
46	109	1,8x7x740mm	Obechi	Liste	Strip	Leiste	Baguette
2	110	1,8x6x550mm	Obechi	Liste	Strip	Leiste	Baguette
2	111	1,8x5x550mm	Obechi	Liste	Strip	Leiste	Baguette
10	112	1,8x3x550mm	Obechi	Liste	Strip	Leiste	Baguette
5	113	1,8x2x550mm	Obechi	Liste	Strip	Leiste	Baguette
3	114	2,8x5x550mm	Obechi	Liste	Strip	Leiste	Baguette
1	115	5x5x550mm	Obechi	Liste	Strip	Leiste	Baguette
1	116	2x2x600mm	Obechi	Liste	Strip	Leiste	Baguette
3	117	0,7x1x550mm	Mahogany	Liste	Strip	Leiste	Baguette
1	118	0,7x2x550mm	Mahogany	Liste	Strip	Leiste	Baguette
29	119	0,7x4x550mm	Annegré	Liste	Strip	Leiste	Baguette
1	120	ø12x30mm	Ramin	Rundstok	Round stick	Rundstab	Baguette ronde
1	121	2mm x-veneér	1090L-B	Redningsbåd	Lifeboat	Rettungsboot	Canot de sauvetage
22	122	1 bag		Master	Masts	Masten	Mât
1	123		9009S	Sejl	Sailcloth	Segelstoff	Tissu de voile
1	124			Tegning	Plan	Plan	Plans
1	125			Byggevejledning	Building instr.	Bauanleitung	Instr. de montage
1	126		FL115	Flag	Flag	Flagge	Drapeau
1	127	2mm x-veneér	1090L-A	Redningsbåd	Lifeboat	Rettungsboot	Canot de sauvetage
1	128	2mm x-veneér	1090L-B	Redningsbåd	Lifeboat	Rettungsboot	Canot de sauvetage
1	129	2mm x-veneér	1090L-B	Redningsbåd	Lifeboat	Rettungsboot	Canot de sauvetage
1	130	2mm x-veneér	1090L-B	Redningsbåd	Lifeboat	Rettungsboot	Canot de sauvetage
1	131	2mm x-veneér	1090L-B	Redningsbåd	Lifeboat	Rettungsboot	Canot de sauvetage
1	132	2mm x-veneér	1090L-A	Redningsbåd	Lifeboat	Rettungsboot	Canot de sauvetage
1	133	2mm x-veneér	1090L-A	Redningsbåd	Lifeboat	Rettungsboot	Canot de sauvetage
1	134	1mm x-veneér	1091L	Redningsbåd	Lifeboat	Rettungsboot	Canot de sauvetage

1	135	1mm x-veneér	1091L	Redningsbåd	Lifeboat	Rettungsboot	Canot de sauvetage
1	136	2mm x-veneér	1090L-A	Redningsbåd	Lifeboat	Rettungsboot	Canot de sauvetage
1	F73	30m		Rigningstråd	Rigging thread	Takelgarn	Fil de greement
1	F72	30m		Rigningstråd	Rigging thread	Takelgarn	Fil de greement
1	F71	50m		Rigningstråd	Rigging thread	Takelgarn	Fil de greement
1	F70	100m		Rigningstråd	Rigging thread	Takelgarn	Fil de greement

Table of contents for fittings kit "Bounty"

Pcs.	No.	Dimension		DK	GB	D	F
1	F22A	ø 0,5mm		Kobbertråd	Copperthread	Kupferdraht	Fil de cuivre
2	F41	12mm		Klyds	Hawsehole	Klüsen	Ecubiérs
1	F51	ø24mm		Ror	Rudder	Ruder	Gouvernail
64	F54	8mm		Kofilnagle	Belaying pin	Belegnägel	Cabillots
136	F697	5mm		Blok	Block	Blöcke	Poulies
10	F698	5mm		Blok	Block	Blöcke	Poulies
64	F695	ø5mm		Jomfru	Dead eye	Jungfern	Cap de mouton
2	F89	51mm		Anker	Anchor	Anker	Ancre
1	F117	46mm		Skorsten	Funnel	Schornstein	Cheminée
4	F163	40mm	F83	Kanon	Canon	Kanon	Canon
4	F164			Lavet	Carriage	Lafette	Affut de canon
52	F696	ø7mm		Jomfru	Dead eye	Jungfern	Cap de mouton
14	F700	7mm		Blok	Block	Blöcke	Poulies
40	F330	10mm		Søm	Pin	Nägel	Clous
1	F236	ø8mm		Klokke	Bell	Glocken	Cloche
40	F285	5,5mm		Øjebolt	Eye bolt	Augenbolzen	Pitons
4	F291	ø5mm		Rulle	Pulley	Rollen	Poulies
24	F317	ø4mm		Køje	Portlight	Bullaugen	Hublot
7	F348	9mm		Klampe	Cleat	Klampen	Taquets
10	F378	ø4mm		Mastknop	Mastknop	Masttop	Pommes de mat
3	F379	ø5mm		Mastknop	Mastknop	Masttop	Pommes de mat
1	F409	ø1,5x250mm		Messingtråd	Brasswire	Messingdraht	Fil de laiton
62	F488	ø3mm		Perle	Pearl	Perlen	Perle
10	F495	24mm		Kanon	Canon	Kanon	Canon
30	F537	25mm		Røstjern	Chainplate	Rüsteisen	Cadènes
10	F540	10x14mm		Lavet	Carriage	Lafette	Affut de canon
8	F671	20x6mm	Brass	Rorbeslag	Rudderfitting	Ruderbeschlag	Gouvernail ganiture

Table of contents for "Bounty" Art. No. 492

Pcs.	No.	Dimension	Material	NL	E	I	P
1	1	4mm x-veneér	1087L	Spant	Cuaderna	Ordinata	Armacão
1	2	4mm x-veneér	1087L	Spant	Cuaderna	Ordinata	Armacão
1	3	4mm x-veneér	1088L	Spant	Cuaderna	Ordinata	Armacão
1	4	4mm x-veneér	1087L	Spant	Cuaderna	Ordinata	Armacão
1	5	4mm x-veneér	1088L	Spant	Cuaderna	Ordinata	Armacão
1	6	4mm x-veneér	1087L	Spant	Cuaderna	Ordinata	Armacão
1	7	4mm x-veneér	1087L	Spant	Cuaderna	Ordinata	Armacão
1	8	4mm x-veneér	1088L	Spant	Cuaderna	Ordinata	Armacão
1	9	4mm x-veneér	1088L	Spant	Cuaderna	Ordinata	Armacão
1	10	4mm x-veneér	1087L	Spant	Cuaderna	Ordinata	Armacão
1	11	4mm x-veneér	1087L	Voorsteven	Proa	Ruota di prua	Proa
1	12	4mm x-veneér	1087L	Achtersteven	Roda trasera	Dritto de poppa	Popa
1	13	4mm x-veneér	1087L	Spant	Cuaderna	Ordinata	Armacão
1	14	4mm x-veneér	1087L	Spant	Cuaderna	Ordinata	Armacão
2	14a	4mm x-veneér	1087L	Hulpstukken	Pieza de ayuda	Pezzo ausiliario	Suporte do fundo
2	15	4mm x-veneér	1088L	Spant	Cuaderna	Ordinata	Armacão
2	16	4mm x-veneér	1088L	Spant	Cuaderna	Ordinata	Armacão
2	17	4mm x-veneér	1088L	Spant	Cuaderna	Ordinata	Armacão
1	18	4mm x-veneér	1087L	Mastvoeten	Soporte del palo	Piede d'albero	Degrau do mastro
1	19	4mm x-veneér	1087L	Mastvoeten	Soporte del palo	Piede d'albero	Degrau do mastro
1	20	4mm x-veneér	1087L	Mastvoeten	Soporte del palo	Piede d'albero	Degrau do mastro
1	21	4mm x-veneér	1087L	Roer	Timón	Timone	Leme
1	22	4mm x-veneér	1087L	Hulpstukken	Pieza de ayuda	Pezzo ausiliario	Suporte do fundo
2	23	2mm x-veneér	1090L-A	Dek	Cubierta	Ponte	Deck
2	24	2mm x-veneér	1090L-B	Hulpstukken	Pieza de ayuda	Pezzo ausiliario	Suporte do fundo
2	25	2mm x-veneér	1090L-A	Hulpstukken	Pieza de ayuda	Pezzo ausiliario	Suporte do fundo
2	26a	2mm x-veneér	1090L-A	Roer	Timón	Timone	Leme
2	27	2mm x-veneér	1090L-A	Bekledingstrips	Listones de forro	Listelli fasciame	Tiras
2	28a	2mm x-veneér	1090L-B	Kajuit	Cámara	Cabina	Cabine
4	28b	2mm x-veneér	1090L-B	Kajuit	Cámara	Cabina	Cabine
2	28c	2mm x-veneér	1090L-A	Kajuit	Cámara	Cabina	Cabine
2	28d	2mm x-veneér	1090L-B	Kajuit	Cámara	Cabina	Cabine
1	28e	2mm x-veneér	1090L-B	Reling	Borda	Parapetto	Amurada
2	29	2mm x-veneér	1090L-A	Kajuit	Cámara	Cabina	Cabine
3	29	2mm x-veneér	1090L-B	Kajuit	Cámara	Cabina	Cabine

2	30	2mm x-veneér	1090L-A	Luik	Escotilla	Boccaporto	Bloco da escotilha
1	31	2mm x-veneér	1090L-A	Luik	Escotilla	Boccaporto	Bloco da escotilha
6	32	2mm x-veneér	1090L-A	Winch	Chigre	Verricello	Guincho
4	33	2mm x-veneér	1090L-A	Luik	Escotilla	Boccaporto	Bloco da escotilha
2	34	2mm x-veneér	1090L-B	Top	Cofa	Coffa	Topo
2	35	2mm x-veneér	1090L-B	Hulpstukken vor kiel	Mandibula	Ganasce	Suporte da junção de mastro
2	36	2mm x-veneér	1090L-B	Hulpstukken vor kiel	Mandibula	Ganasce	Suporte da junção de mastro
2	37	2mm x-veneér	1090L-A	Top	Cofa	Coffa	Topo
2	38	2mm x-veneér	1090L-A	Hulpstukken vor kiel	Mandibula	Ganasce	Suporte da junção de mastro
2	39	2mm x-veneér	1090L-B	Hulpstukken vor kiel	Mandibula	Ganasce	Suporte da junção de mastro
1	40	2mm x-veneér	1090L-A	Top	Cofa	Coffa	Topo
1	40	2mm x-veneér	1090L-B	Top	Cofa	Coffa	Topo
2	41	2mm x-veneér	1090L-B	Hulpstukken vor kiel	Mandibula	Ganasce	Suporte da junção da mastro
1	42	2mm x-veneér	1090L-A	Spant	Cuaderna	Ordinata	Armazém
1	43	2mm x-veneér	1090L-A	Spant	Cuaderna	Ordinata	Armazém
2	44	2mm x-veneér	1090L-A	Rusten	Enrejado	Asse di catene	Correntes do Mastro principal
2	45	2mm x-veneér	1090L-B	Rusten	Enrejado	Asse di catene	Correntes do Mastro principal
2	46	2mm x-veneér	1090L-B	Rusten	Enrejado	Asse di catene	Correntes do Mastro principal
2	47	2mm x-veneér	1090L-B	Reling	Borda	Parapetto	Amurada
2	48	2mm x-veneér	1090L-A	Winch	Chigre	Vericello	Guincho
2	49	2mm x-veneér	1090L-A	Winch	Chigre	Vericello	Guincho
2	50	2mm x-veneér	1090L-A	Gaffel	Pico de congrejo	Randa	Carangueja
1	51	3mm x-veneér	1089L	Stücke vor voorsteven	Piezas de proa	Componenti per dritto di prua	Pecas da popa
1	52a	3mm x-veneér	1089L	Achtersteven	Roda trasera	Dritto di poppa	Popa
2	52b	3mm x-veneér	1089L	Achtersteven	Roda trasera	Dritto di poppa	Popa
2	52c	3mm x-veneér	1089L	Achtersteven	Roda trasera	Dritto di poppa	Popa
4	53	3mm x-veneér	1089L	Spant	Cuaderna	Ordinata	Armazém
6	54	3mm x-veneér	1089L	Spant	Cuaderna	Ordinata	Armazém
12	54a	3mm x-veneér	1089L	Spant	Cuaderna	Ordinata	Armazém
4	55a	3mm x-veneér	1089L	Boegbeeld	Galeón	Vessillifero	Beque
2	55b	3mm x-veneér	1089L	Boegbeeld	Galeón	Vessillifero	Beque
2	56	3mm x-veneér	1089L	Galerie	Galeria	Galleria	Galeria
2	57	3mm x-veneér	1089L	Stuurkolom	Barra del timón	Posto de timone	Bloco do timão
3	58	3mm x-veneér	1089L	Standaard	Grada	Supporto	Apoio
4	59	3mm x-veneér	1089L	Halter	Consola	Consolle	Suporte
2	60	3mm x-veneér	1089L	Top	Cofa	Coffa	Topo
2	61	3mm x-veneér	1089L	Top	Cofa	Coffa	Topo

2	62	3mm x-veneér	1089L	Top	Cofa	Coffa	Topo
2	63	3mm x-veneér	1089L	Bramzaling	Cofa	Crocetta	Juncão inferior do mastro
2	64	3mm x-veneér	1089L	Bramzaling	Cofa	Crocetta	Juncão inferior do mastro
1	65	3mm x-veneér	1089L	Ezelshoofd	Herraje de juntapalos	Testa di moro	Pega
1	66	3mm x-veneér	1089L	Ezelshoofd	Herraje de juntapalos	Testa di moro	Pega
1	67	3mm x-veneér	1089L	Ezelshoofd	Herraje de juntapalos	Testa di moro	Pega
2	68	3mm x-veneér	1089L	Halter	Consola	Consolle	Suporte
1	69	3mm x-veneér	1089L	Mastvoeten	Soporte del palo	Piede d'albero	Degrau do mastro
1	70	3mm x-veneér	1089L	Mastvoeten	Soporte del palo	Piede d'albero	Degrau do mastro
1	71	3mm x-veneér	1089L	Mastvoeten	Soporte del palo	Piede d'albero	Degrau do mastro
1	72	3mm x-veneér	1089L	Ezelshoofd	Herraje de juntapalos	Testa di moro	Pega
1	73	3mm x-veneér	1089L	Ezelshoofd	Herraje de juntapalos	Testa di moro	Pega
1	74	3mm x-veneér	1089L	Ezelshoofd	Herraje de juntapalos	Testa di moro	Pega
1	75	3mm x-veneér	1089L	Winch	Chigre	Vericello	Guincho
1	76	3mm x-veneér	1089L	Blok	Bloque	Blocco	Blocos
2	77	3mm x-veneér	1089L	Voor rollen	Rodillos	Per pulegge	Fixador do ovém
1	78	3mm x-veneér	1089L	Balgen	Guindastes	Braccio da carico	Bonecas
1	79	3mm x-veneér	1089L	Roerkoning	Tronco del timón	Tronco del timone	Eixo do leme
1	80	3mm x-veneér	1089L	Tussenstuk	Pieza intermedia	Pezzo centrale	Peca intermédia
10	81	1mm x-veneér	1091L	Galerie	Galeria	Galleria	Galeria
1	82	1mm x-veneér	1091L	Jufferblokken	Virgenes	Testa di montone	Bigota
1	83	1mm x-veneér	1091L	Winch	Chigre	Verricello	Guincho
1	84	1mm x-veneér	1091L	Winch	Chigre	Verricello	Guincho
6	85	1mm x-veneér	1091L	Winch	Chigre	Verricello	Guincho
2	86	1mm x-veneér	1091L	Nagelbank	Banco de cabillas	Cavaletto	Banco dos pinos de amarracão
1	87	1mm x-veneér	1091L	Nagelbank	Banco de cabillas	Cavaletto	Banco dos pinos de amarracão
2	88	1mm x-veneér	1091L	Nagelbank	Banco de cabillas	Cavaletto	Banco dos pinos de amarracão
3	89	1mm x-veneér	1091L	Nagelbank	Banco de cabillas	Cavaletto	Banco dos pinos de amarracão
2	90	2mm x-veneér	1090L-A	Reddingsboot	Bote salvavida	Scialuppa di salvataggio	Bote salva-vidas
2	91	1mm x-veneér	1091L	Verhaalklampen	Bocina	Rinforzo	Tubo do escovém
17	92	1mm x-veneér	1091L	Voor boom	Botalón	Scaletta	Estopa
14	93	1mm x-veneér	1091L	Ladder	Escala	Posto del timone	Escada
2	94	1mm x-veneér	1091L	Stuurkolom	Barra del timón	Galleria	Bloco do timão
1	95	1mm x-veneér	1091L	Galerie	Galeria	Galleria	Galeria
1	96	1mm x-veneér	1091L	Galerie	Galeria	Vessillifero	Galeria
2	97	1mm x-veneér	1091L	Boegbeeld	Galeón	Vessillifero	Beque
2	98	1mm x-veneér	1091L	Boegbeeld	Galeón	Polena	Beque

3	99	4mm x-veneér	1087L	Boegbeeld	Figurón de proa	Bitta	Figura de proa e entalhes
2	100	4mm x-veneér	1088L	Bolder	Bitones	Per campana	Poste de amarracão
1	101	4mm x-veneér	1087L	Voor scheepsbel	Campanilla	Verricello	Amurada de pópa
2	102	4mm x-veneér	1087L	Winch	Chigre	Supporto	Guincho
2	103	4mm x-veneér	1088L	Standaard	Grada	Pezzo centrale	Peca intermédia
2	104	4mm x-veneér	1087L	Tussenstuk	Pieza intermedia	Acetato	Vidros
1	105	50x120mm		Acetaat	Bajada	Listello	Tira
1	106	4x14x500mm	Obechi	Strip	Listón	Listello	Tira
1	107	4x4x600mm	Obechi	Strip	Listón	Listello	Tira
3	108	3x8x550mm	Obechi	Strip	Listón	Listello	Tira
46	109	1,8x7x740mm	Obechi	Strip	Listón	Listello	Tira
2	110	1,8x6x550mm	Obechi	Strip	Listón	Listello	Tira
2	111	1,8x5x550mm	Obechi	Strip	Listón	Listello	Tira
10	112	1,8x3x550mm	Obechi	Strip	Listón	Listello	Tira
5	113	1,8x2x550mm	Obechi	Strip	Listón	Listello	Tira
3	114	2,8x5x550mm	Obechi	Strip	Listón	Listello	Tira
1	115	5x5x550mm	Obechi	Strip	Listón	Listello	Tira
1	116	2x2x600mm	Obechi	Strip	Listón	Listello	Tira
3	117	0,7x1x550mm	Mahogany	Strip	Listón	Listello	Tira
1	118	0,7x2x550mm	Mahogany	Strip	Listón	Listello	Tira
29	119	0,7x4x550mm	Annegré	Strip	Listón	Listello	Tira
1	120	ø12x30mm	Ramin	Rondhout	Barra reronda	Tondino (listello)	Bastão cilíndrico
1	121	2mm x-veneér	1090L-B	Reddingsboot	Bote salvavida	Scialuppa di salvataggio	Bote salva-vidas
22	122	1 bag		Mast	Palos	Albero	Mastro
1	123		9009S	Zeildoek	Vela	Stoffa per le vele	Velas
1	124			Bouwtekening	Ilustración	Piani di costruzione	Planta principal
1	125			Bouwbeschrijving	Instrucciones de construccion	Istruzioni di montaggio	Instruções de montagem
1	126		FL115	Vlag	Bandera	Bandiere	Bandeira
1	127	2mm x-veneér	1090L-A	Reddingsboot	Bote salvavida	Scialuppa di salvataggio	Bote salva-vidas
1	128	2mm x-veneér	1090L-B	Reddingsboot	Bote salvavida	Scialuppa di salvataggio	Bote salva-vidas
1	129	2mm x-veneér	1090L-B	Reddingsboot	Bote salvavida	Scialuppa di salvataggio	Bote salva-vidas
1	130	2mm x-veneér	1090L-B	Reddingsboot	Bote salvavida	Scialuppa di salvataggio	Bote salva-vidas
1	131	2mm x-veneér	1090L-B	Reddingsboot	Bote salvavida	Scialuppa di salvataggio	Bote salva-vidas
1	132	2mm x-veneér	1090L-A	Reddingsboot	Bote salvavida	Scialuppa di salvataggio	Bote salva-vidas
1	133	2mm x-veneér	1090L-A	Reddingsboot	Bote salvavida	Scialuppa di salvataggio	Bote salva-vidas
1	134	1mm x-veneér	1091L	Reddingsboot	Bote salvavida	Scialuppa di salvataggio	Bote salva-vidas
1	135	1mm x-veneér	1091L	Reddingsboot	Bote salvavida	Scialuppa di salvataggio	Bote salva-vidas



1	136	2mm x-veneér	1090L-A	Reddingsboot	Bote salvavida	Scialuppa di salvataggio	Bote salva-vidas
1	F73	30m		Takelgaren	Hilo de oparejo	Filo per manovre	Linha de cordame
1	F72	30m		Takelgaren	Hilo de oparejo	Filo per manovre	Linha de cordame
1	F71	50m		Takelgaren	Hilo de oparejo	Filo per manovre	Linha de cordame
1	F70	100m		Takelgaren	Hilo de oparejo	Filo per manovre	Linha de cordame

Table of contents for fittings kit "Bounty"

Pcs.	No.	Dimension		NL	E	I	P
1	F22A	2,5mm		Koperdraad	Alambre de cabre	Filo in rame	Linha de cobre
2	F41	12mm		Verhaalklampen	Bocina	Rinforzo	Tubo do escovém
1	F51	ø24mm		Roer	Timón	Timone	Leme
64	F54	8mm		Korvijnnagel	Cabillas	Ribattino	Pino de amarração
136	F697	5mm		Blokken	Polea	Blocchi	Blocos
10	F698	5mm		Blokken	Polea	Blocchi	Blocos
64	F695	ø5mm		Jufferblokken	Virgenes	Testa di montone	Bigota
2	F89	51mm		Ander	Ancla	Ancora	Àncora
1	F117	46mm		Schorrsteen	Chimenea	Camine	Chamine
4	F163	40mm	F83	Kanon	Cañon	Cannone	Canhão
4	F164			Kanonwagen	Cureña	Affusto	Carro
52	F696	ø7mm		Jufferblokken	Virgenes	Testa di montone	Bigota
14	F700	7mm		Blokken	Polea	Blocchi	Blocos
40	F330	10mm		Spijkertjes	Clavo	Chiodi	Pino
1	F236	ø8mm		Scheepbel	Campanilla	Campana	Sino
40	F285	5,5mm		Oogbauten	Pernos de cánamo	Bullone ad occhio	Ferrolho
4	F291	ø5mm		Rollen	Rodillos	Pulegge	Roldana
24	F317	ø4mm		Patrijspoort	Potillas	Oblò	Aro de escotilha
7	F348	9mm		Kickers	Cornamusas	Galloccia	Ponto de amarra
10	F378	ø4mm		Mastkloot	Extremo superior de palo	Estremità superiore dell'albero	Topo de mastro
3	F379	ø5mm		Mastkloot	Extremo superior de palo	Estremità superiore dell'albero	Topo de mastro
1	F409	ø1,5x250mm		Messingdraad	Hilo de latón	Filo in ottone	Fio de latão
62	F488	ø3mm		Perle	Perla	Perla	Luz de alerta (pérola)
10	F495	24mm		Kanon	Cañon	Cannone	Canhão
30	F537	25mm		Puttings	Cadenote	Landra	Fixador do ovém
10	F540	10x14mm		Kanonwagen	Cureña	Affusto	Carro
8	F671	20x6mm	Brass	Roerbeslag	Bisagra de timón	Accessori	Fittings para o leme

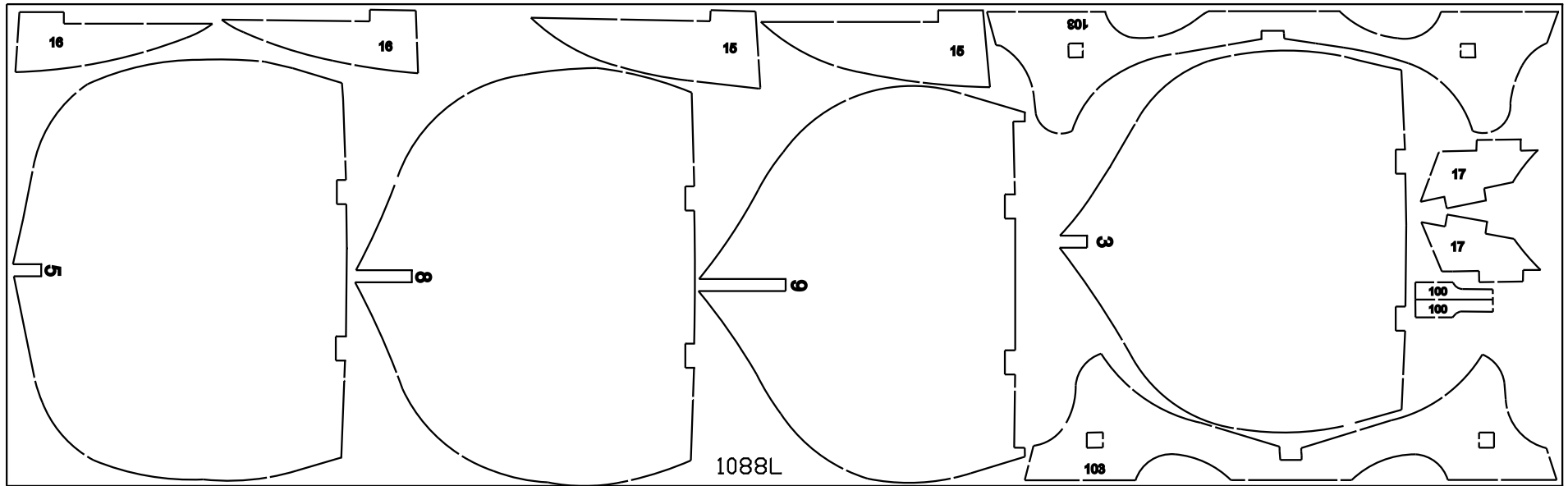
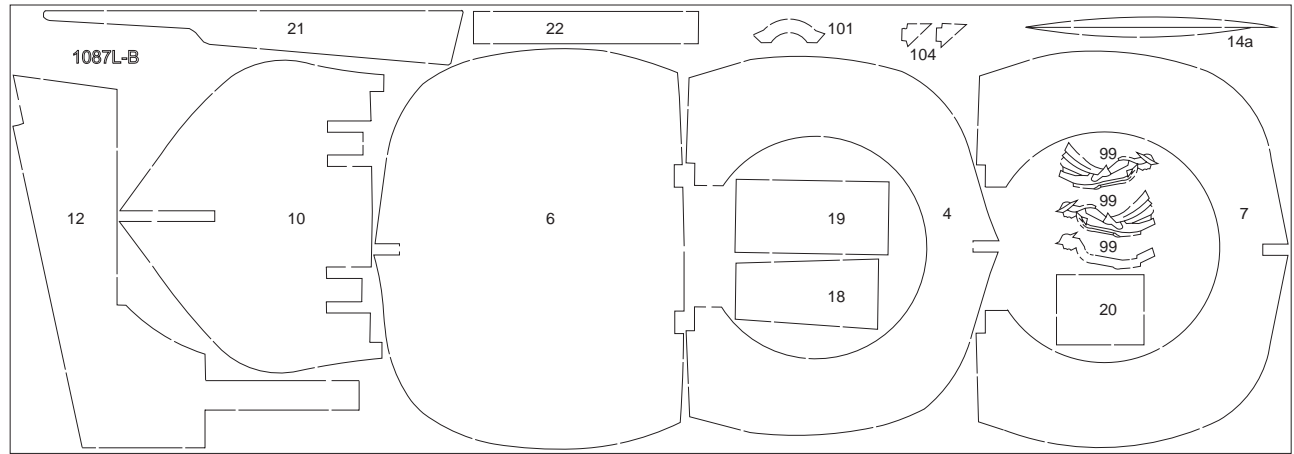
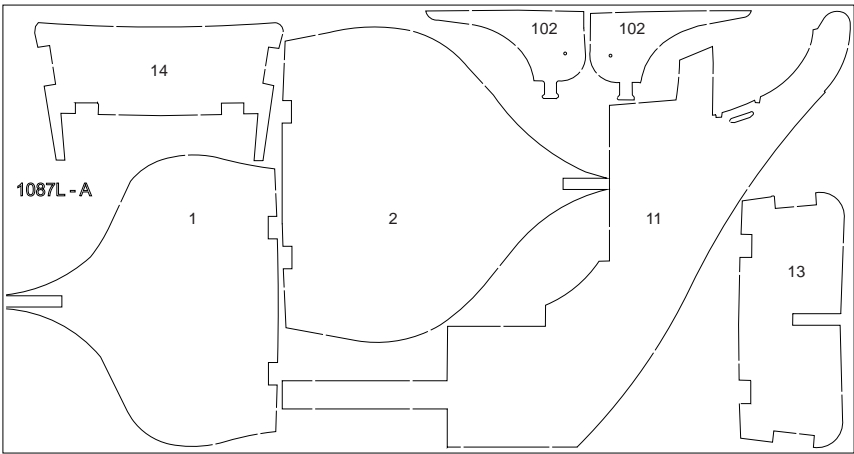

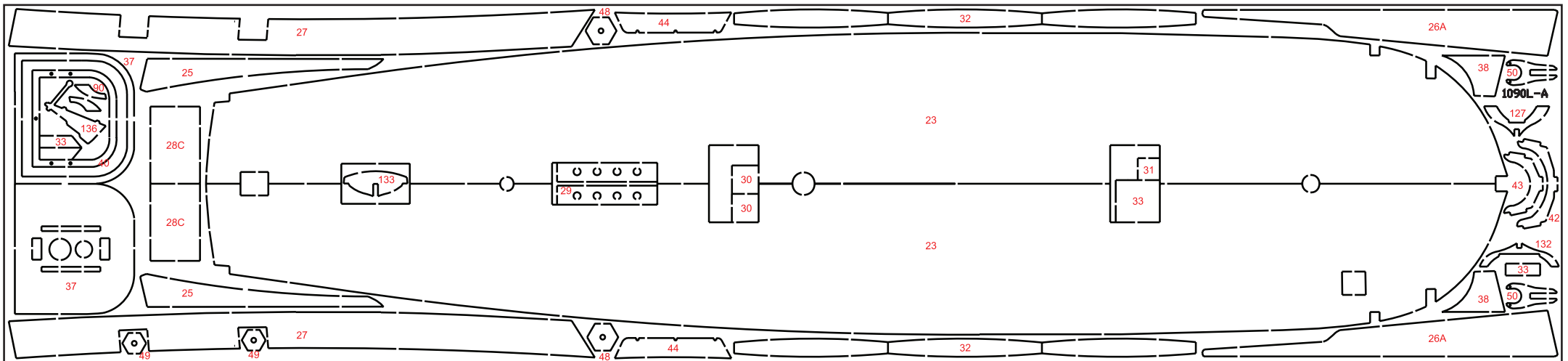
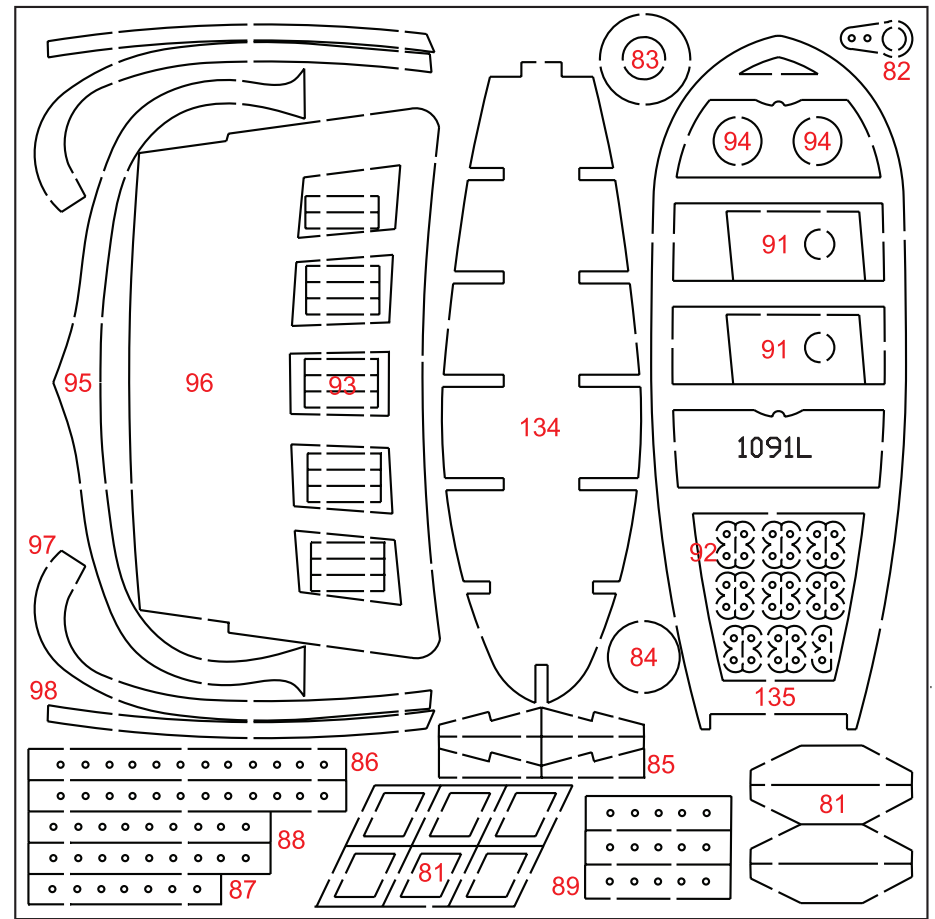
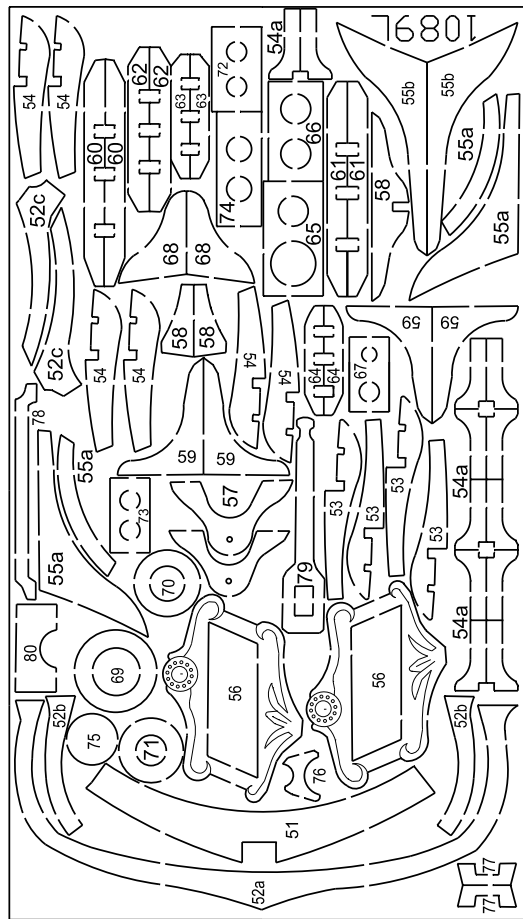
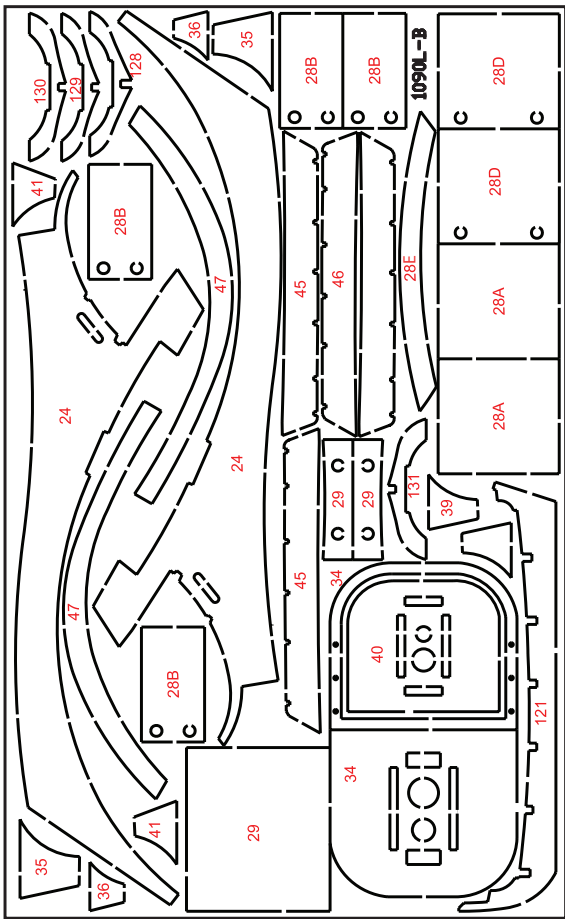

Fig. 1

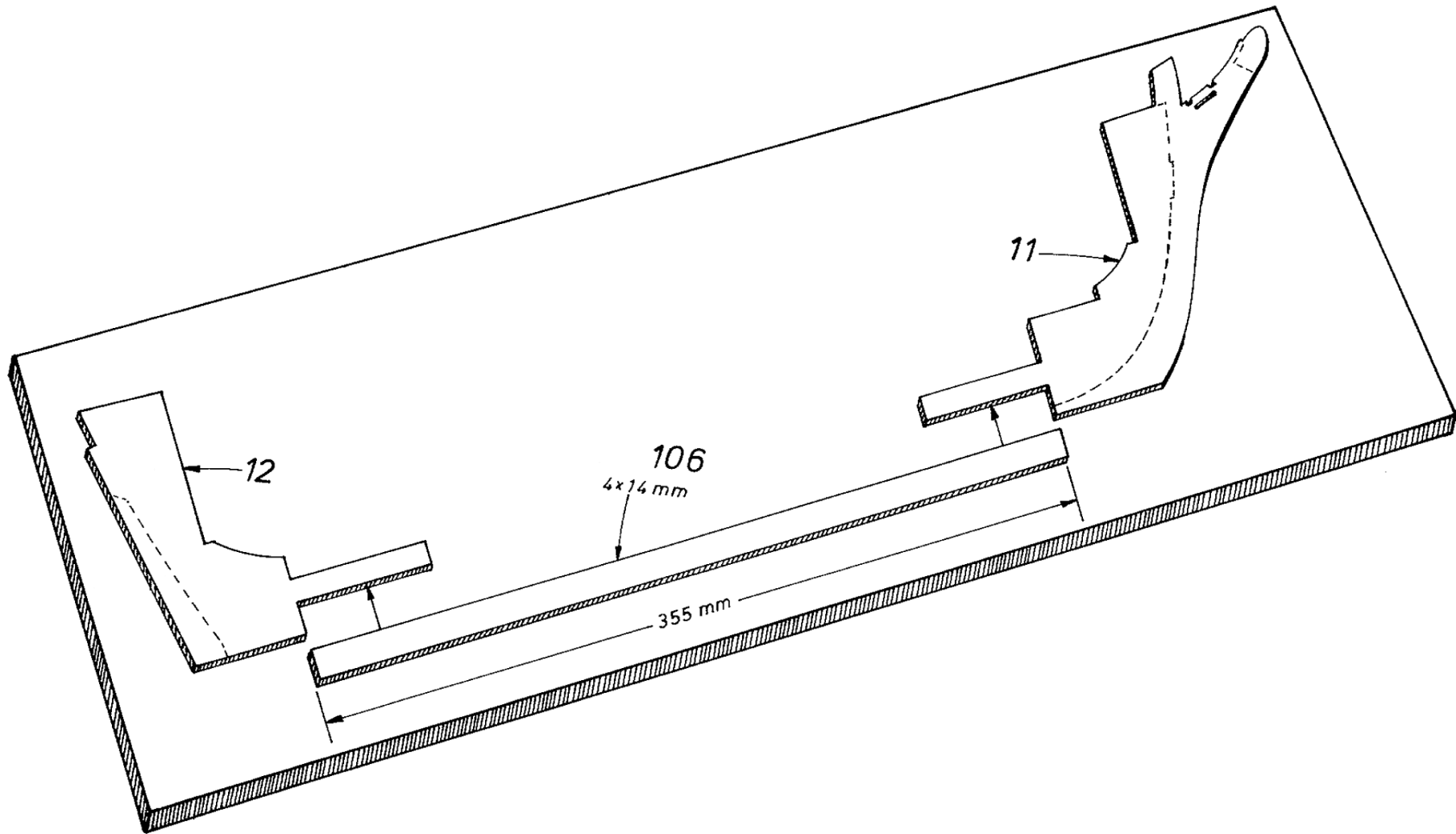

Fig. 2

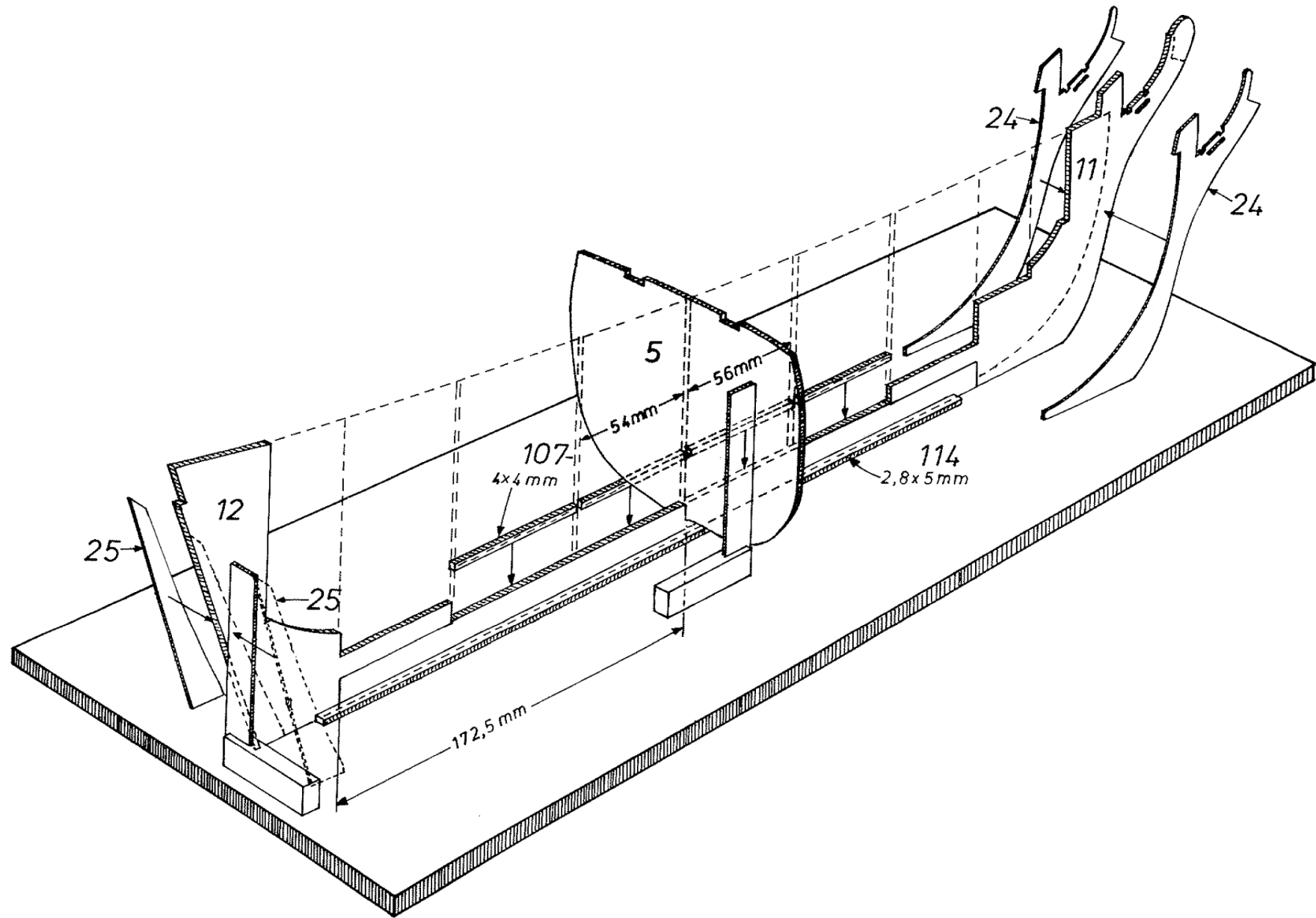

Fig. 3

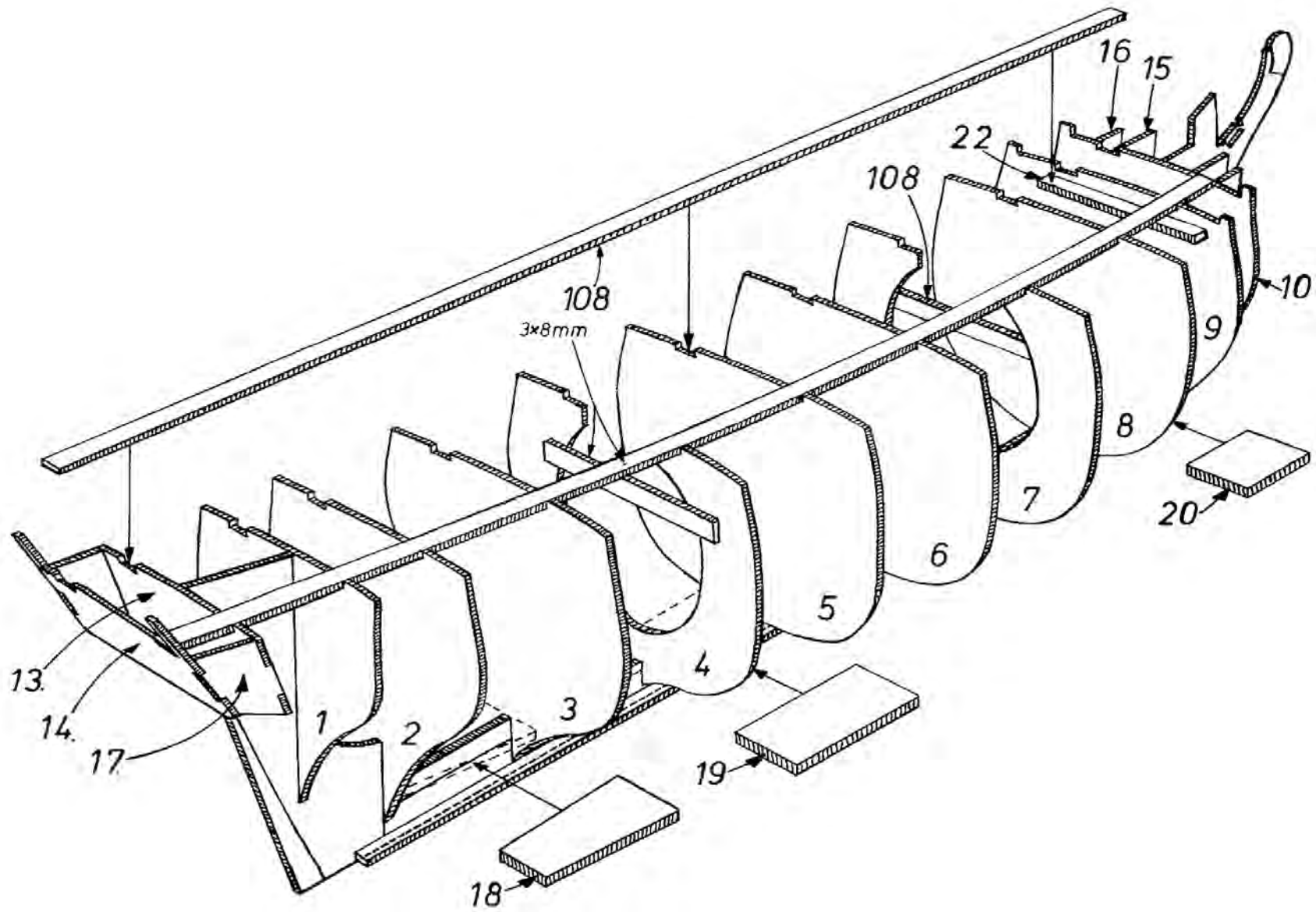



Fig. 4

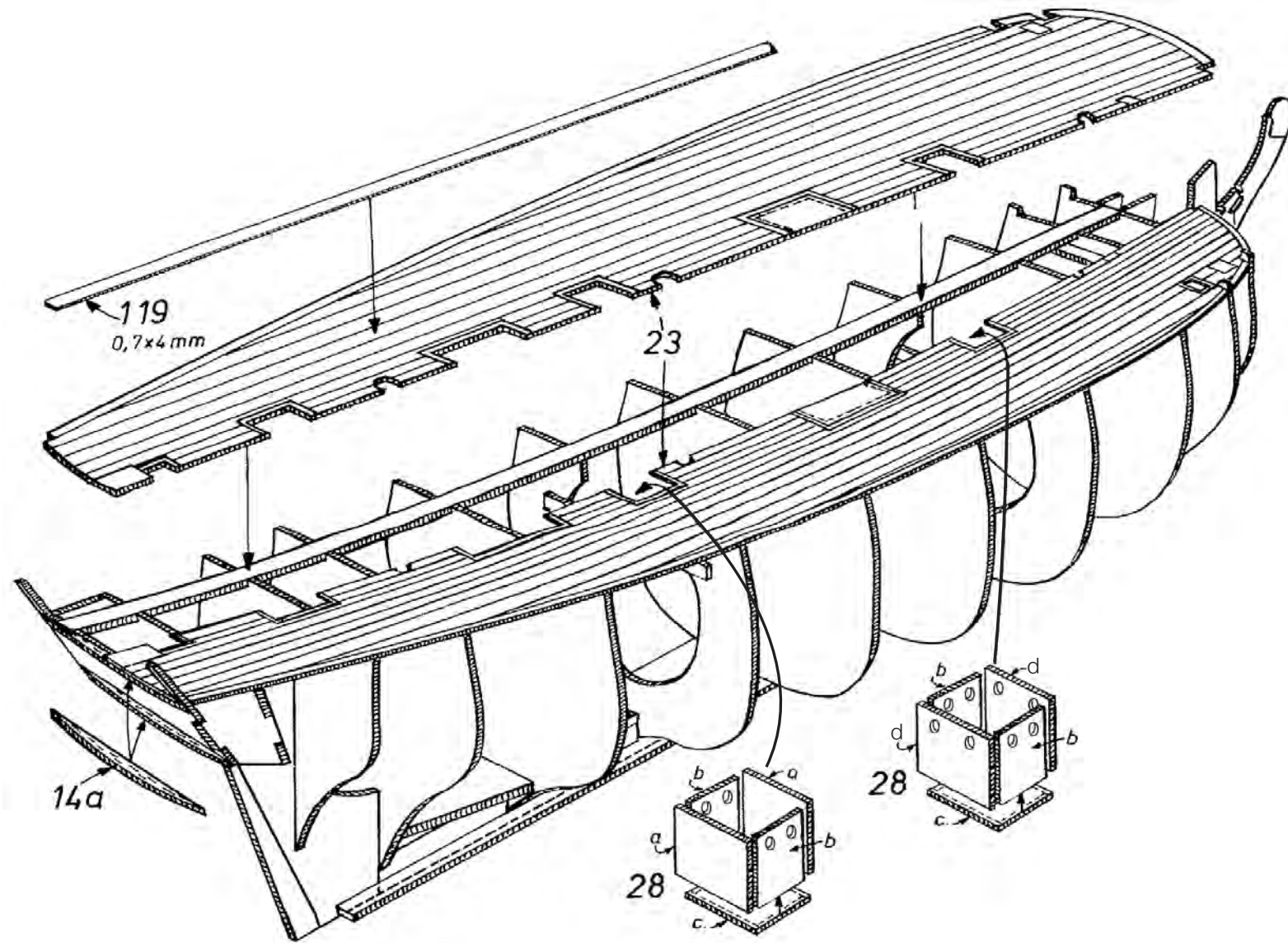

Fig. 5

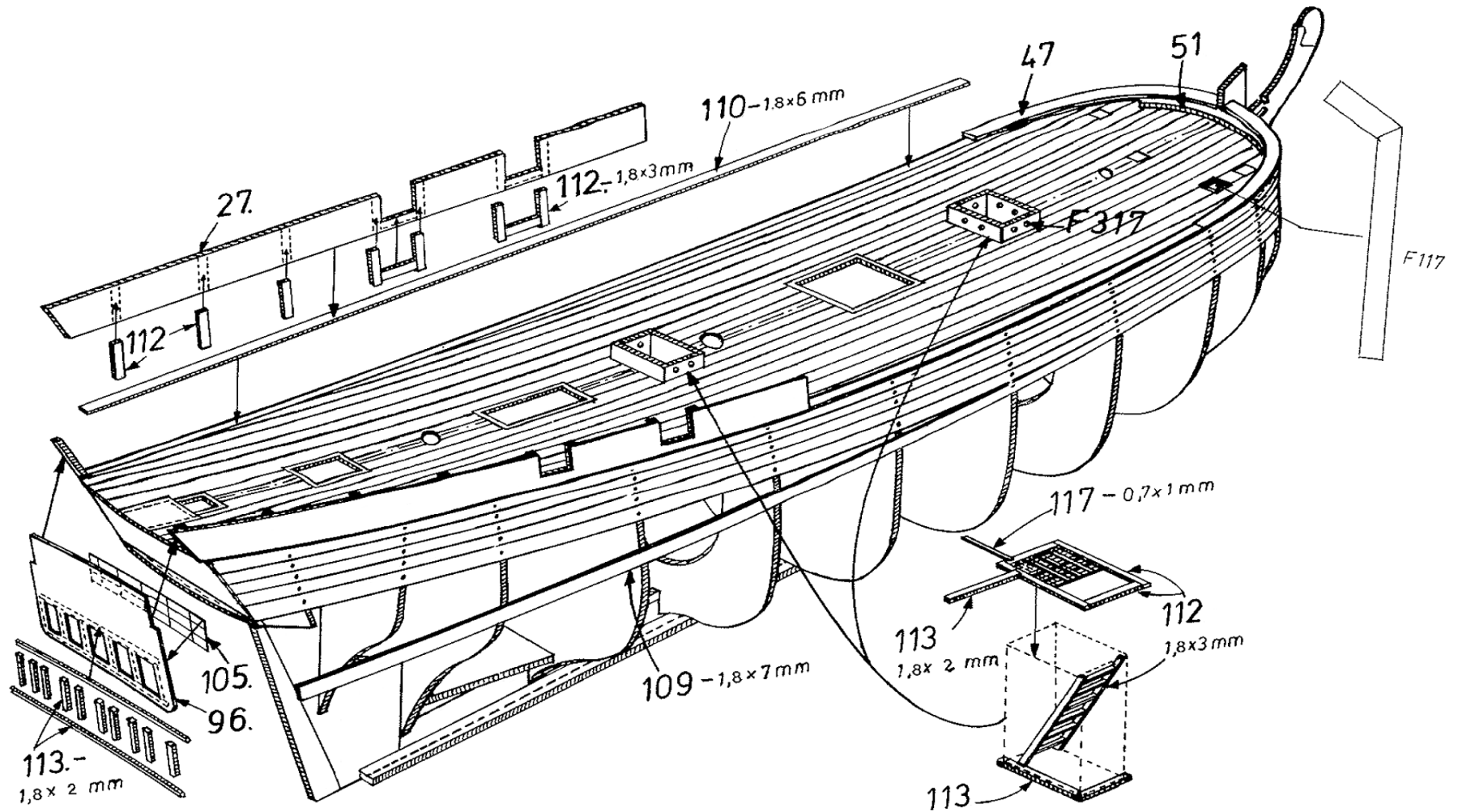

Fig. 6

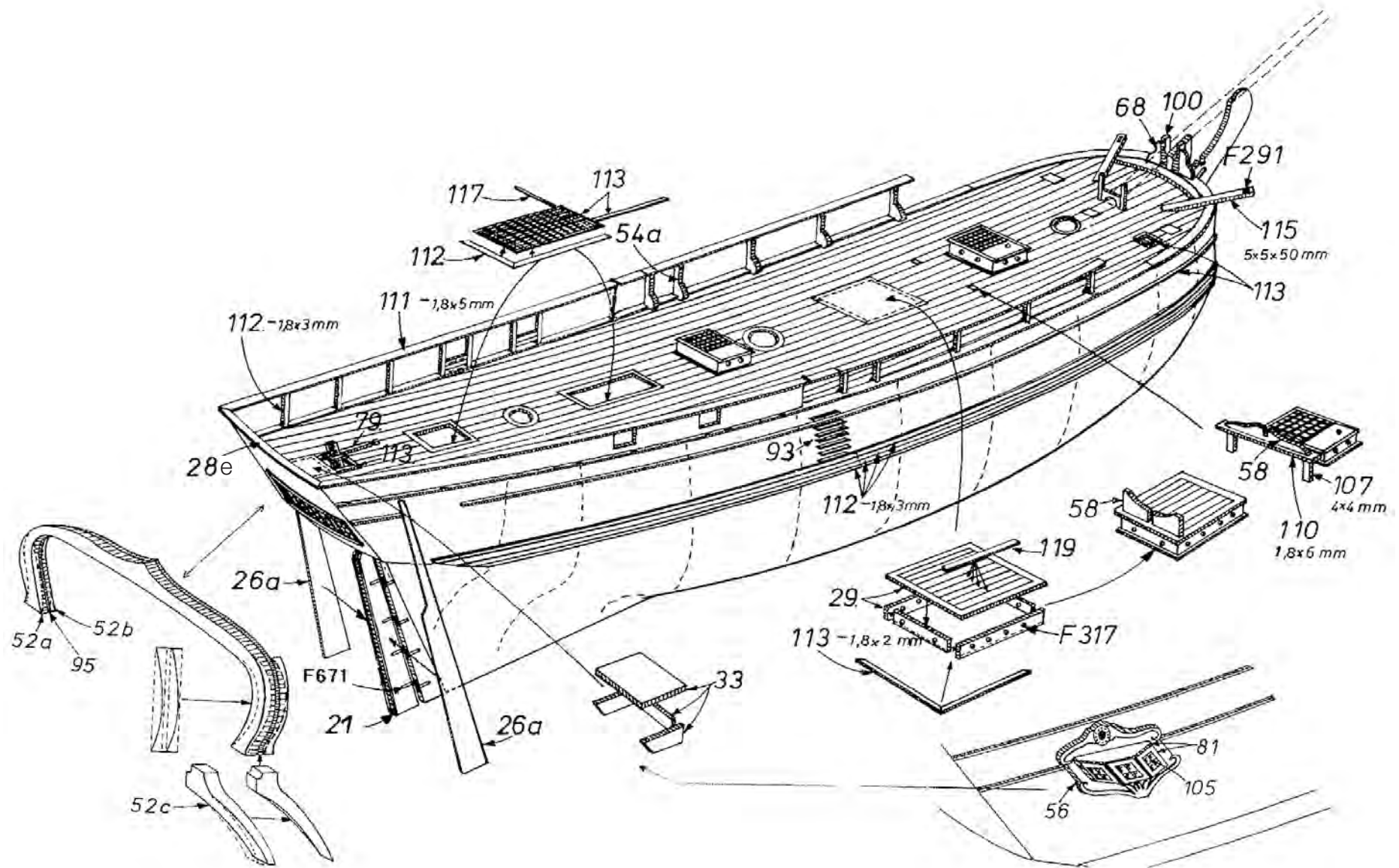



Fig. 7

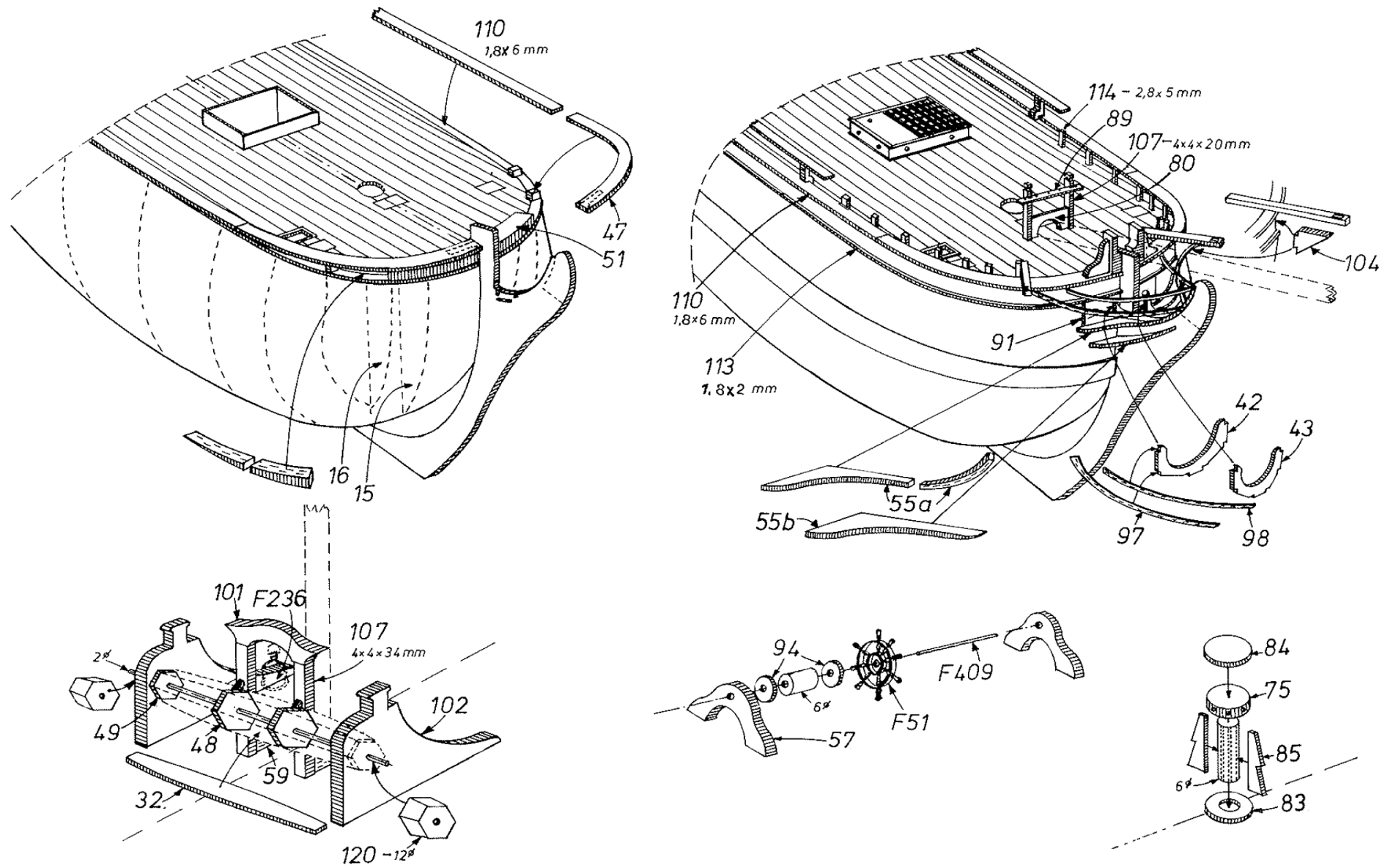

Fig. 8

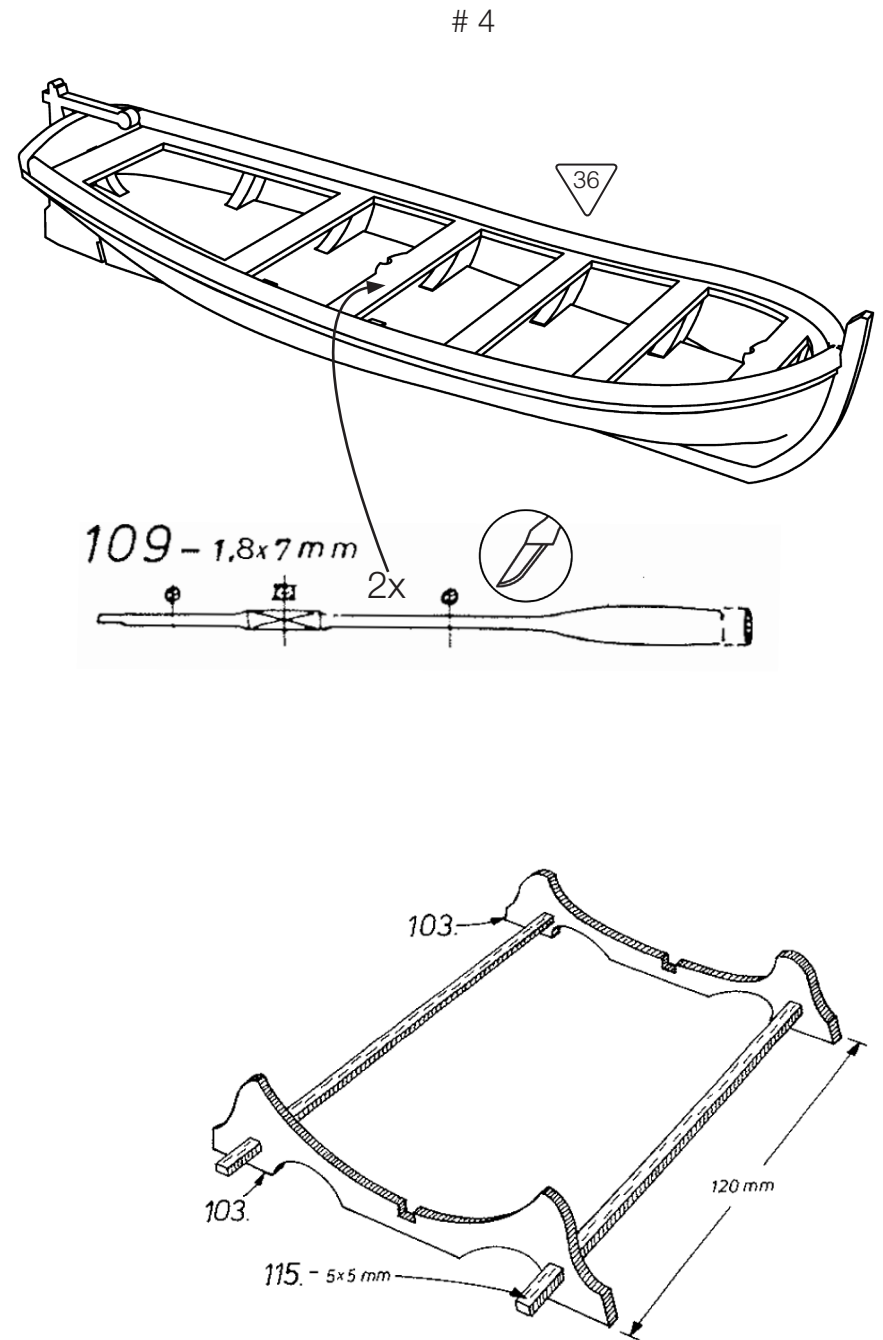
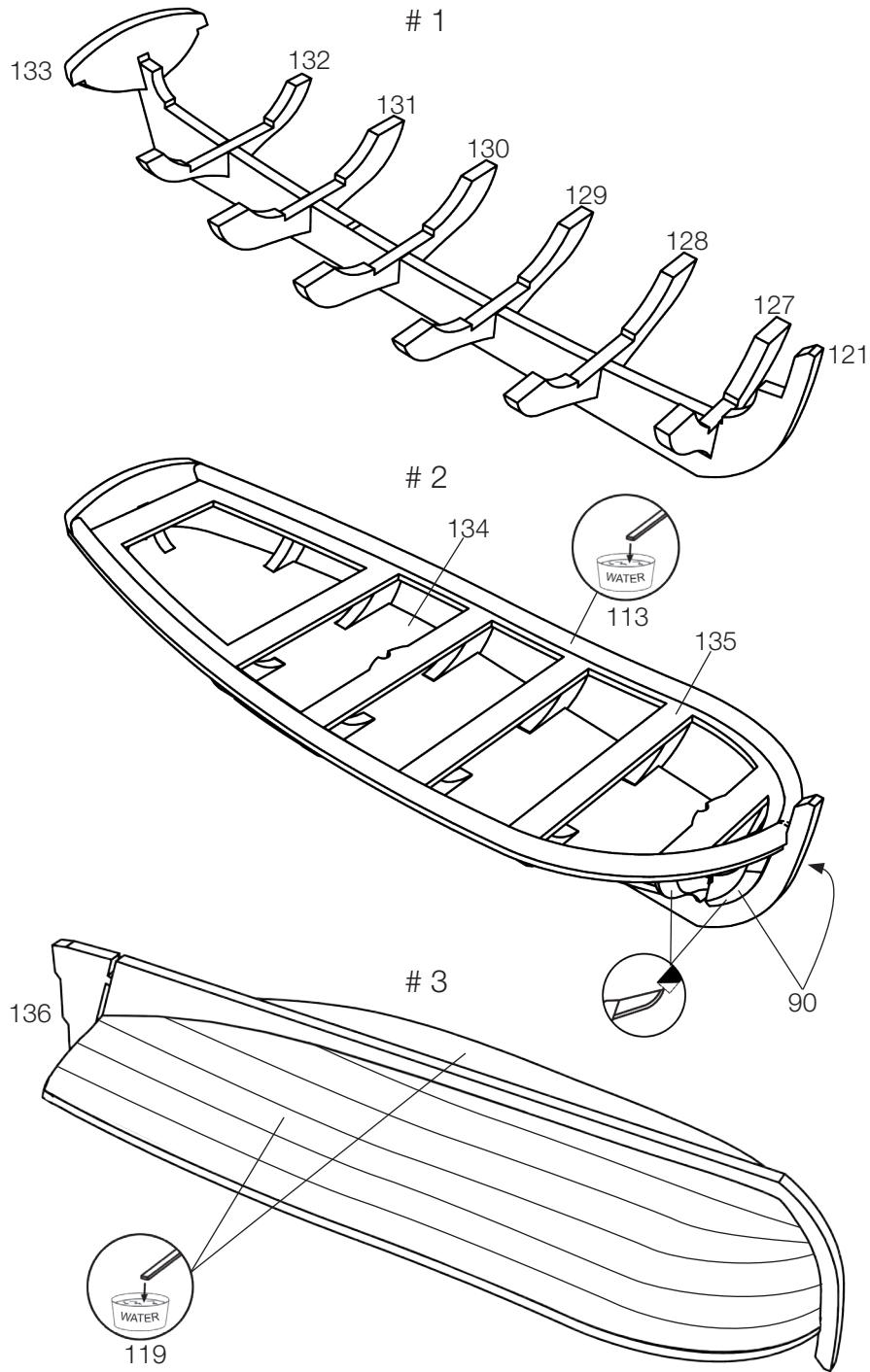
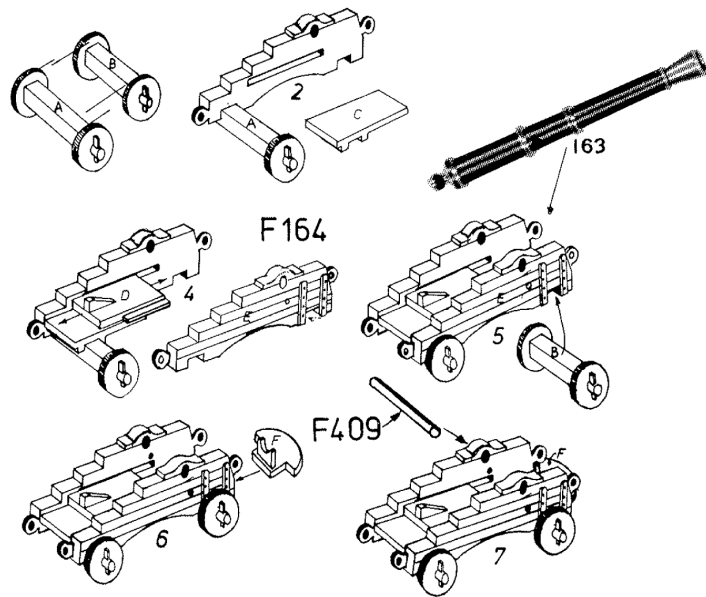
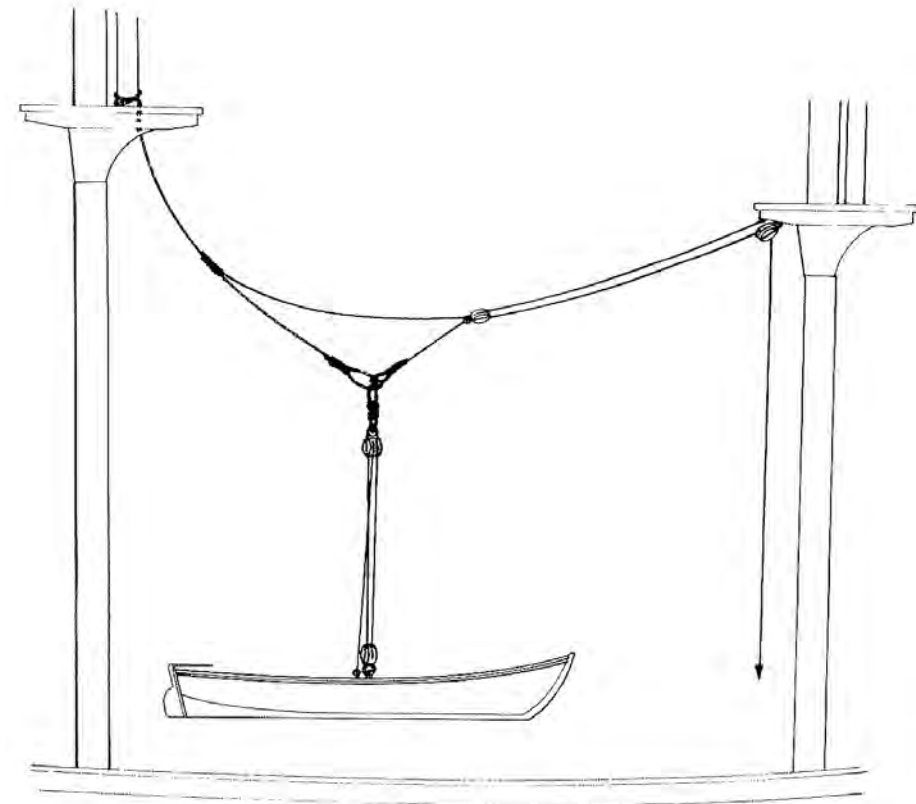

Fig. 9



S1	F71	R1	F72	L1	F73
S2	F71	R2	F73	L2	F72
S3	F71	R3	F73	L3	F72
S4	F71	R4	F73	L4	F71
S5	F71	R5	F73	L5	F71
S6	F71	R6	F72	L6	F72
S7	F71	R7	F72	L7	F71
S8	F71	R8	F73	L8	F71
S9	F73	R9	F73	L9	F72
S10	F71	R10	F72	L10	F71
S11	F71	R11	F73	L11	F71
S12	F71	R12	F72	L12	F72
S13	F71	R13	F72	L13	F72
S14	F71	R14	F73	L14	F71
S15	F73	R15	F72	L15	F72
S16	F71	R16	F73	L16	F71
S17	F71	R17	F72	L17	F71
S18	F71	R18	F73	L18	F72
S19	F71	R19	F72	L19	F71
S20	F71	R20	F72	L20	F71
S21	F71	R21	F72	L21	F71
S22	F71	R22	F72	L22	F71
S23	F71			L23	F71
S24	F72			L24	F71
S25	F71			L25	F71
				L26	F71
				L27	F71
				L28	F71
				L29	F71
				L30	F71
				L31	F71
				L32	F71
				L33	F71



Til denne model er mahogni bejdse og farver med følgende numre nødvendige:

For this model is mahogany stain and colours with the following numbers should be used:

Für dieses Modell sind Mahagoni Beize und Farben mit den folgenden Nummern notwendig:

Pour ce modèle, le mordant et les couleurs avec les numéros suivants doivent être employées:

Voor dit model zijn kleuren met de volgende nummers nodig:

Para est modelo se necesitan mordiente et colores con los siguientes números:

Per questo modello occorrono inchiostro tinteggiatore "mogano" e colori con questi numeri:

Pinte o modelo com tintura cõr Mogno e as cõres sugeridas da Billing Boats:

Billing 1	=	White
Billing 11	=	Black
Billing 16	=	Gold
Billing 17	=	Clear Poly
Billing 36	=	Bejdse/Stain/Beize/Mordant/Beize/Mordient



Fig. 10

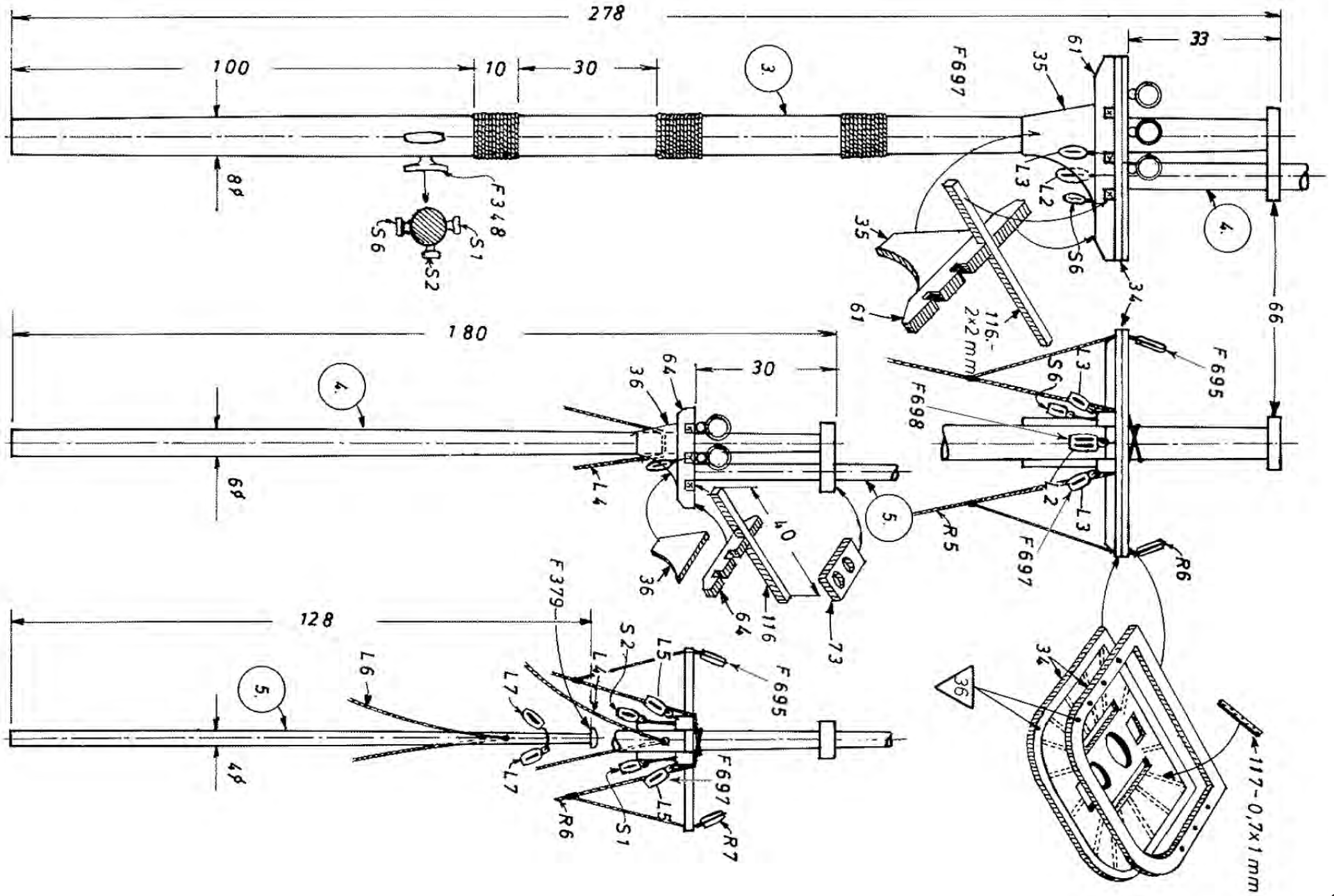



Fig. 12

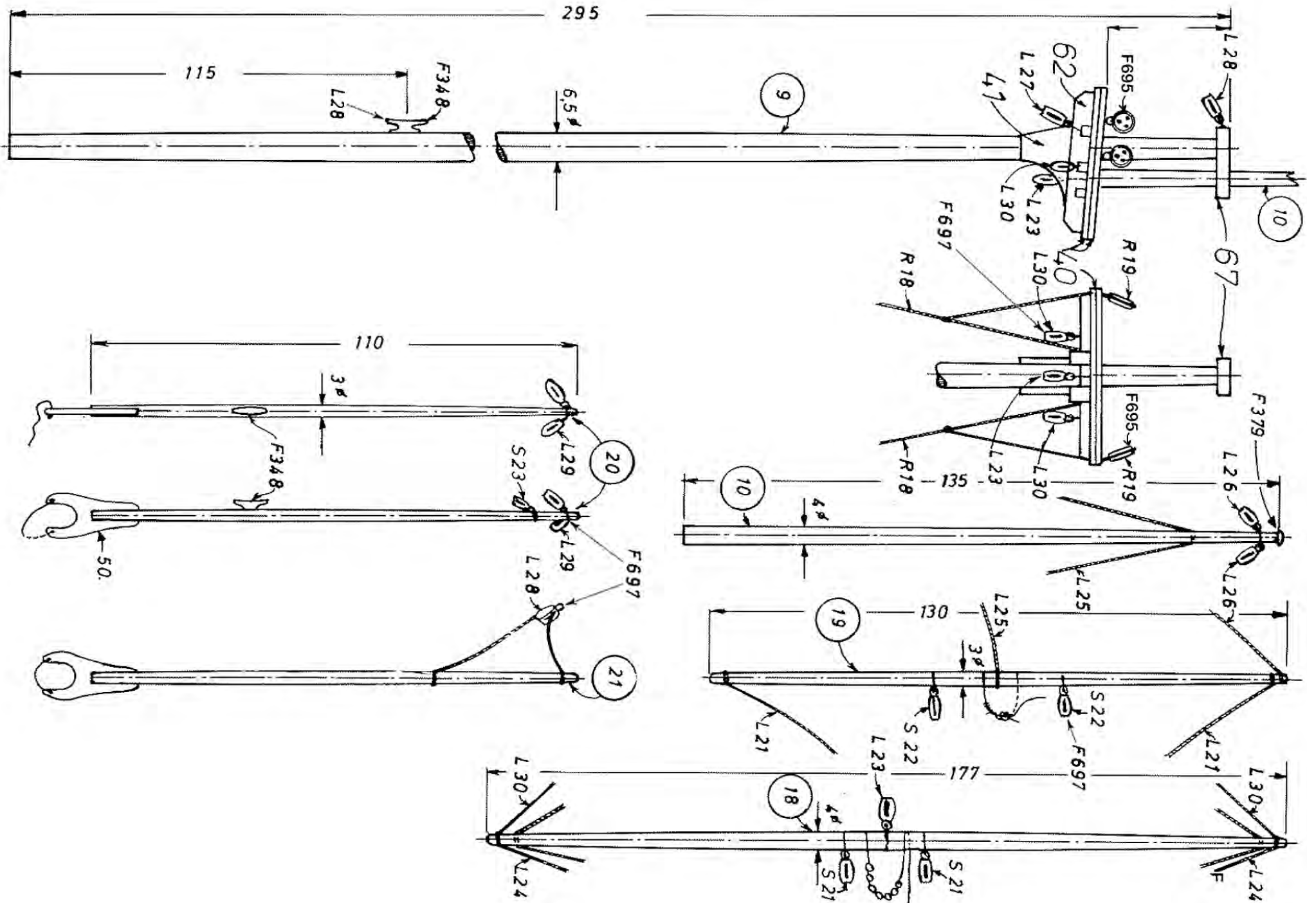



Fig. 13

